

X-ray Absorption Spectroscopy

Grant Bunker
Professor and Chair
Department of Physics
Illinois Institute of Technology

- Overview of XAFS Spectroscopy and its uses
- Theory (a little)
- Experiment
- Data Analysis
- Conclusion

Acknowledgements

- ~39 years in XAFS
- Ed Stern, Dale Sayers, Farrel Lytle, John Rehr, Gerd Rosenbaum, Bruce Bunker, many others...
- XAFS community that grew from it
- Students and postdocs

Ed Stern, Dale Sayers, and Farrel Lytle receiving Warren Prize 1979



Sadly, Ed recently passed away at age 85 on May 17, 2016. Ed was an inspired physicist who always strived to get to the essence of things. He would invent or create whatever was necessary to do research. He also was a kind, thoughtful, person with a good sense of humor. He will be missed.



Some Stern
Lab denizens
~ 1983

concise guide for those new to XAFS

Introduction to **XAFS**

X-ray absorption fine structure spectroscopy (XAFS) is a powerful and versatile technique for studying structures of materials in chemistry, physics, biology, and other fields. This textbook is a comprehensive, practical guide to carrying out and interpreting XAFS experiments.

Assuming only undergraduate-level physics and mathematics, the textbook is ideally suited for graduate students in physics and chemistry starting XAFS-based research. It contains concise executable example programs in Mathematica 7.

The textbook addresses experiment, theory, and data analysis, but is not tied to specific data analysis programs or philosophies. This makes it accessible to a broad audience in the sciences, and a useful guide for researchers entering the subject.

Supplementary material available at www.cambridge.org/9780521767750

- Mathematica code from the book
- Related Mathematica programs
- Worked data analysis examples

GRANT BUNKER is Professor of Physics at the Illinois Institute of Technology. He has over 30 years' experience in all aspects of XAFS spectroscopy, from technique development, instrumentation, and computation, to applications in biology, chemistry, and physics.

Cover illustration: © Alan Crosthwaite.

Cover designed by Hart McLeod Ltd

CAMBRIDGE
UNIVERSITY PRESS
www.cambridge.org



BUNKER

Introduction to XAFS



Introduction to **XAFS**

A Practical Guide to
X-ray Absorption Fine Structure Spectroscopy

GRANT BUNKER

CAMBRIDGE

What is XAFS?

- X-ray Absorption Fine Structure spectroscopy uses the x-ray photoelectric effect and the wave nature of the electron to determine local structures around selected atomic species in materials
- Unlike x-ray diffraction, it does not require long range translational order – it works equally well in amorphous materials, liquids, (poly)crystalline solids, and molecular gases.
- XANES (near-edge structure) can be sensitive to charge transfer, orbital occupancy, and symmetry.

EXAFS experiment

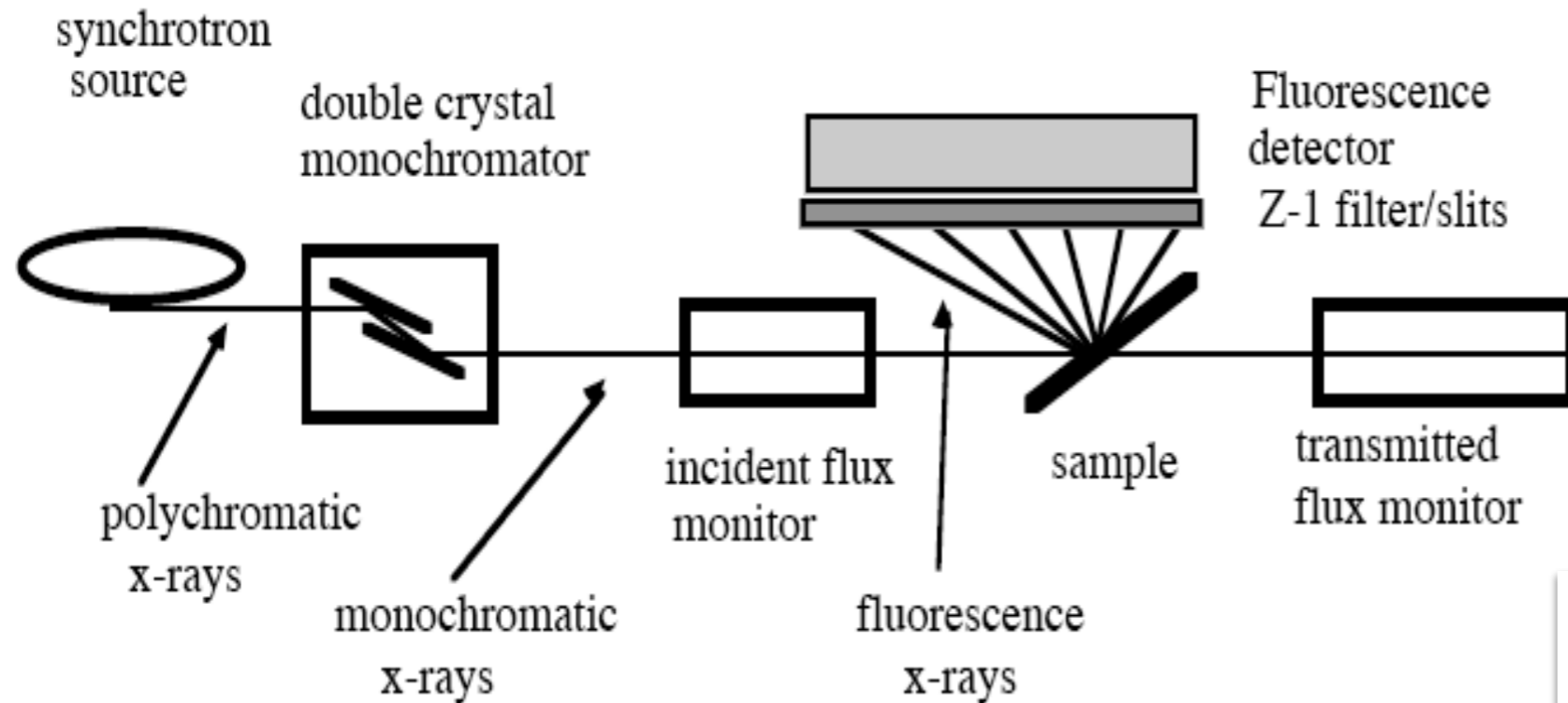

Figure 1 – Schematic XAFS experiment

$$\frac{I}{I_0} = \exp(-\mu(E)x)$$

The X-ray absorption coefficient is the central quantity of interest. It is analogous to absorbance in UV-vis spectroscopy, and it is proportional to $f''(E)$.

Absorption Edges

example: Iodine

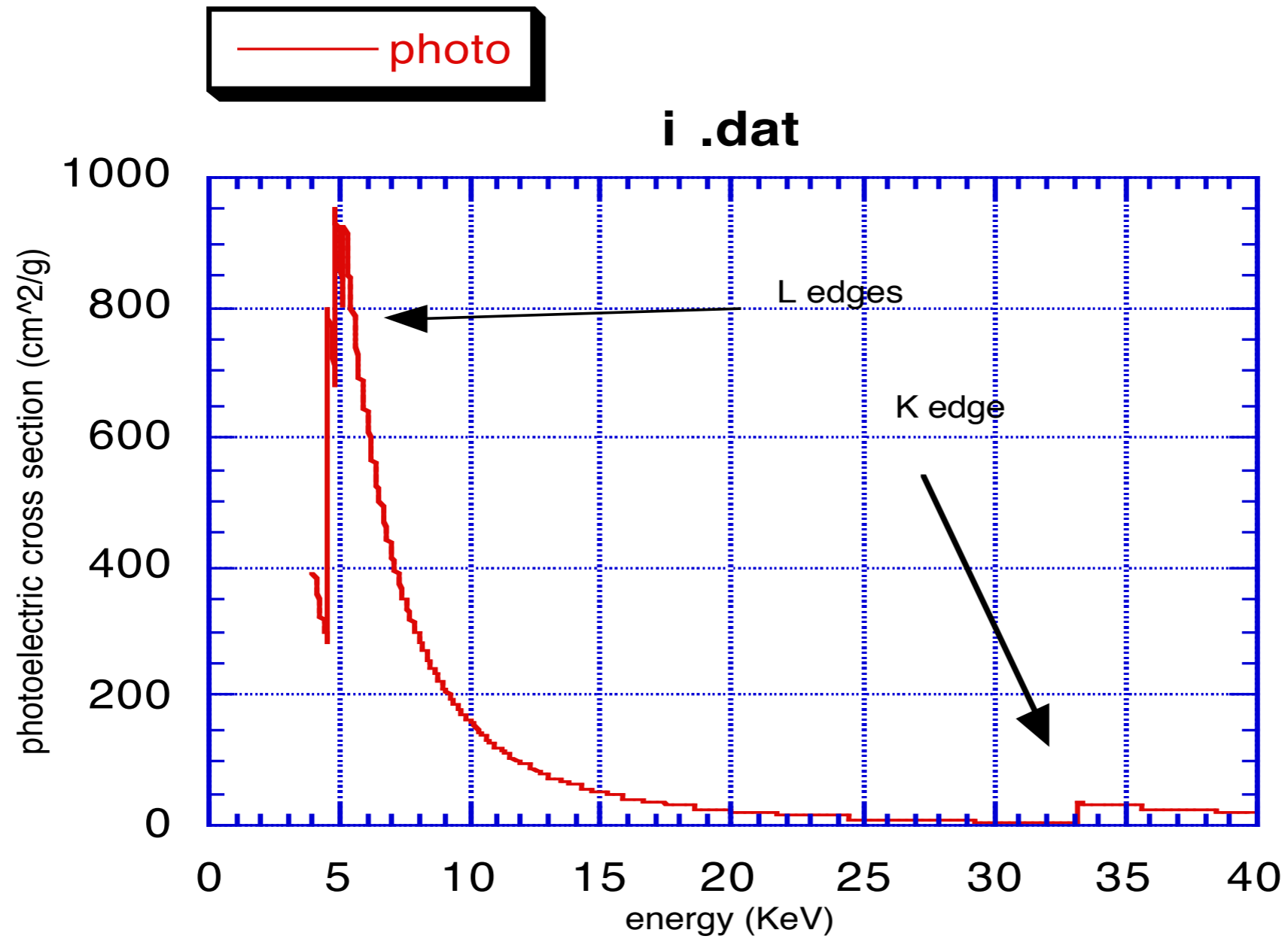

zoom in on L-edges

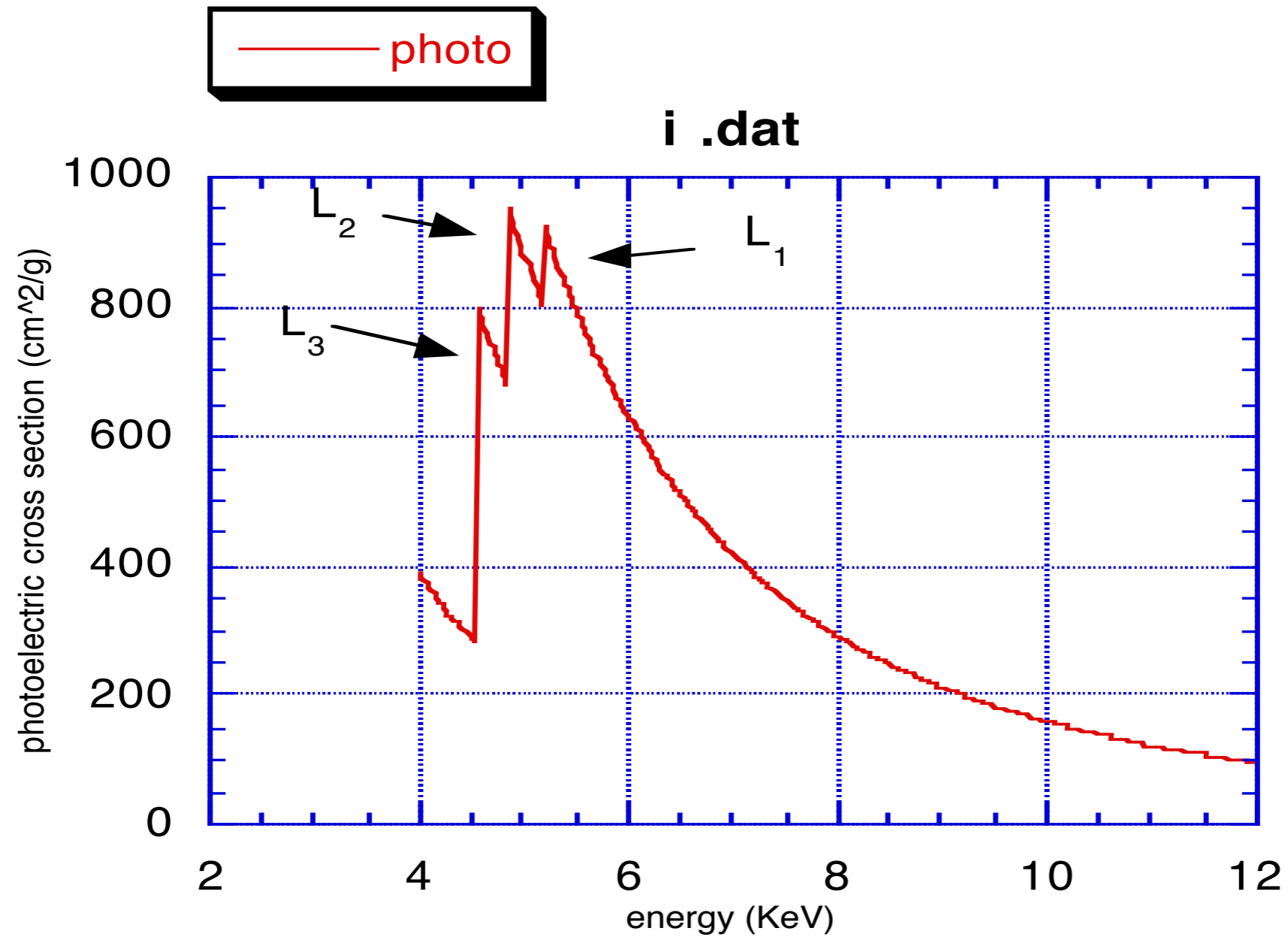

Molecular gases GeH₄, GeH₃Cl, GeCl₄ tetrahedral coordination

Bouldin et al, 1988

GEH4.020

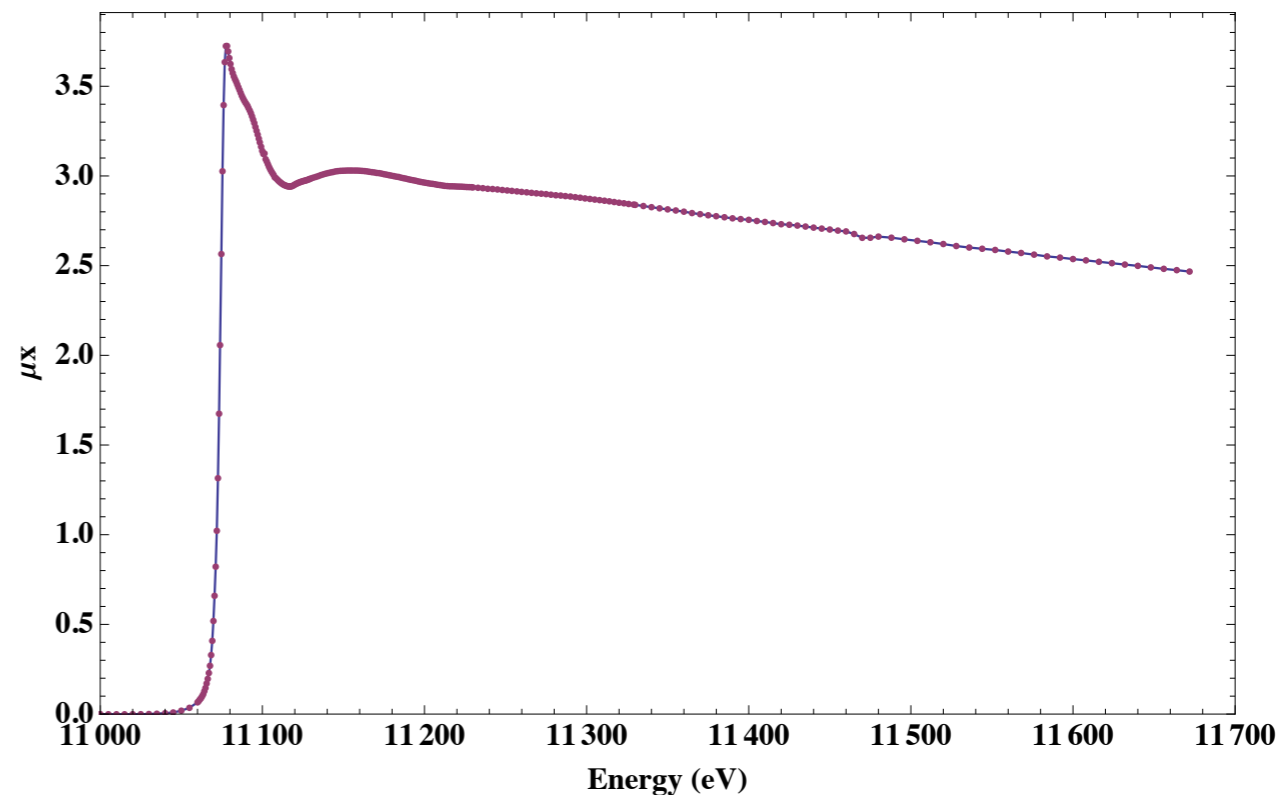

GEH3CL.001

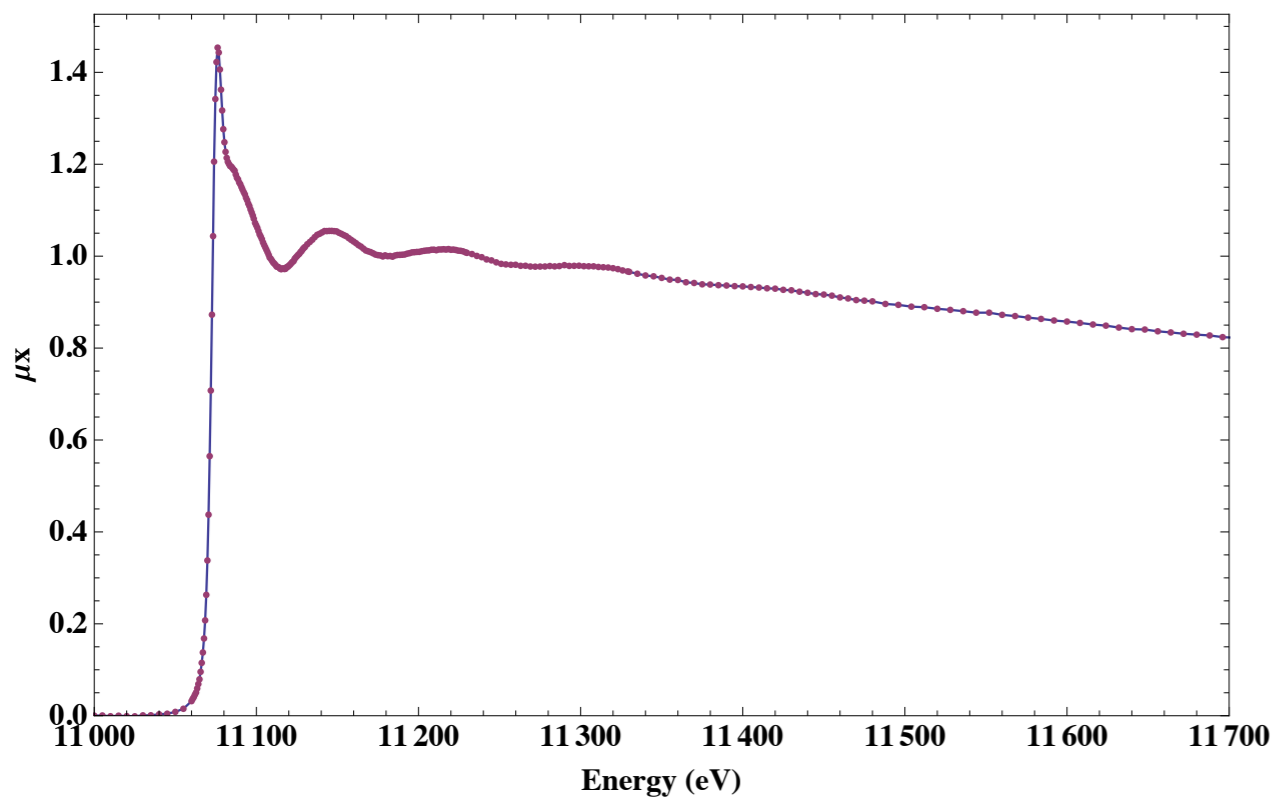

GECL4.001

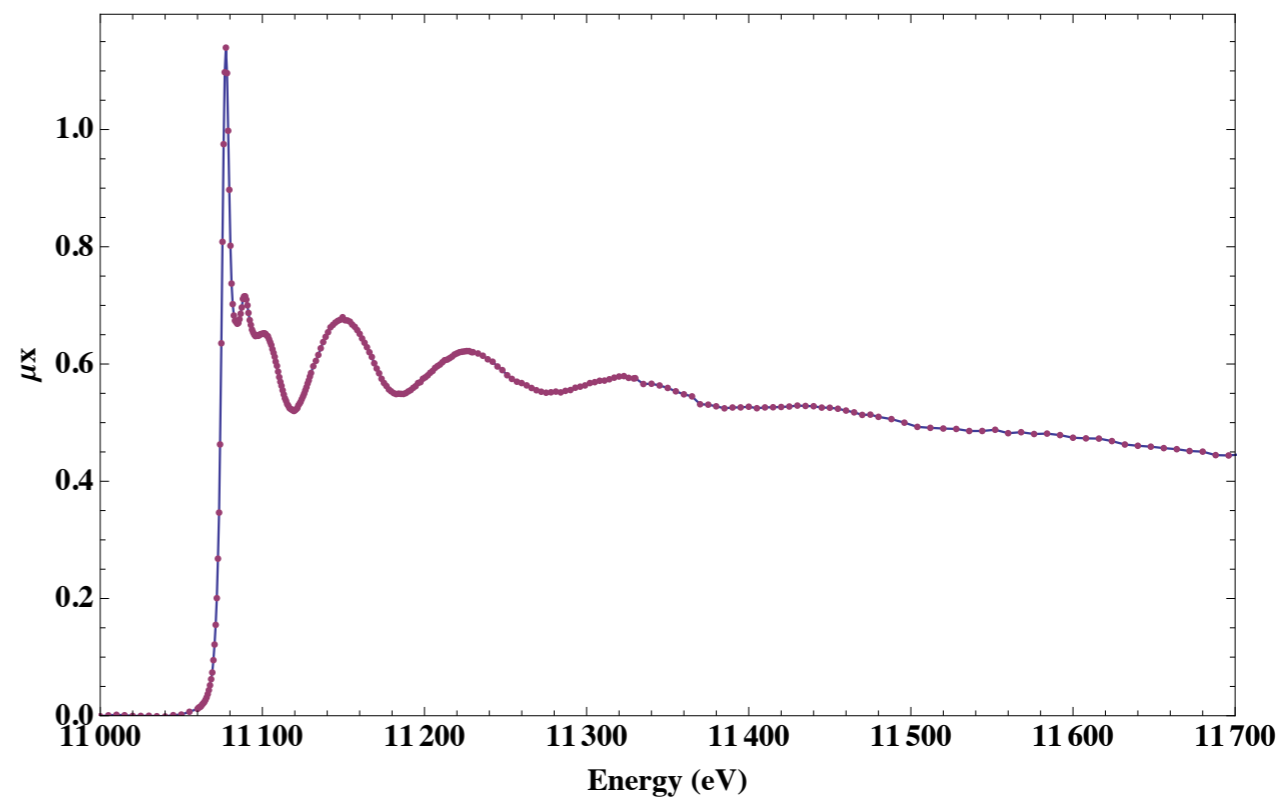

ZnS transmission

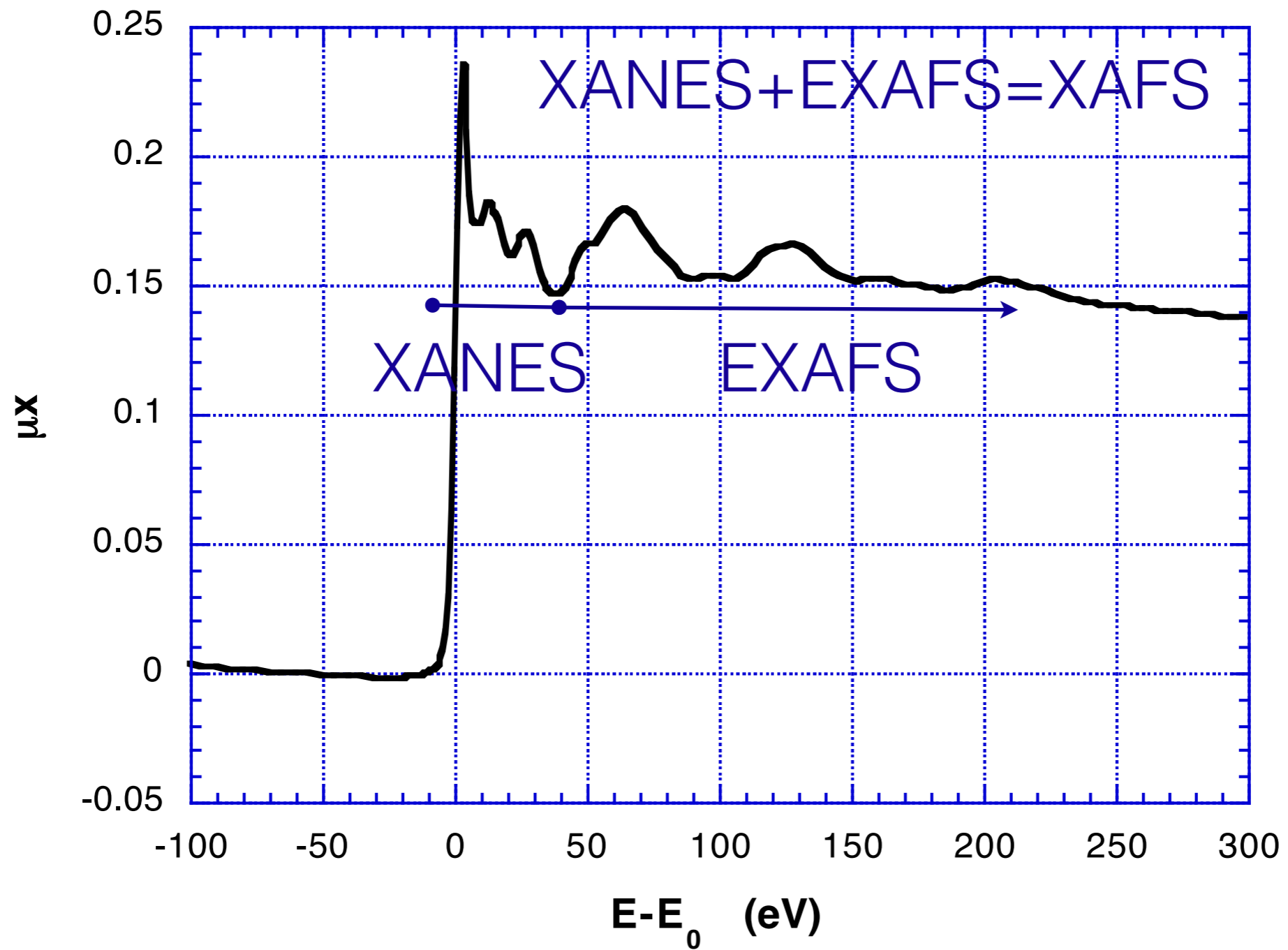

Zn Cys/His complexes: XAFS encodes structure

From top: S3N, S2N2, S4 Zn peptides

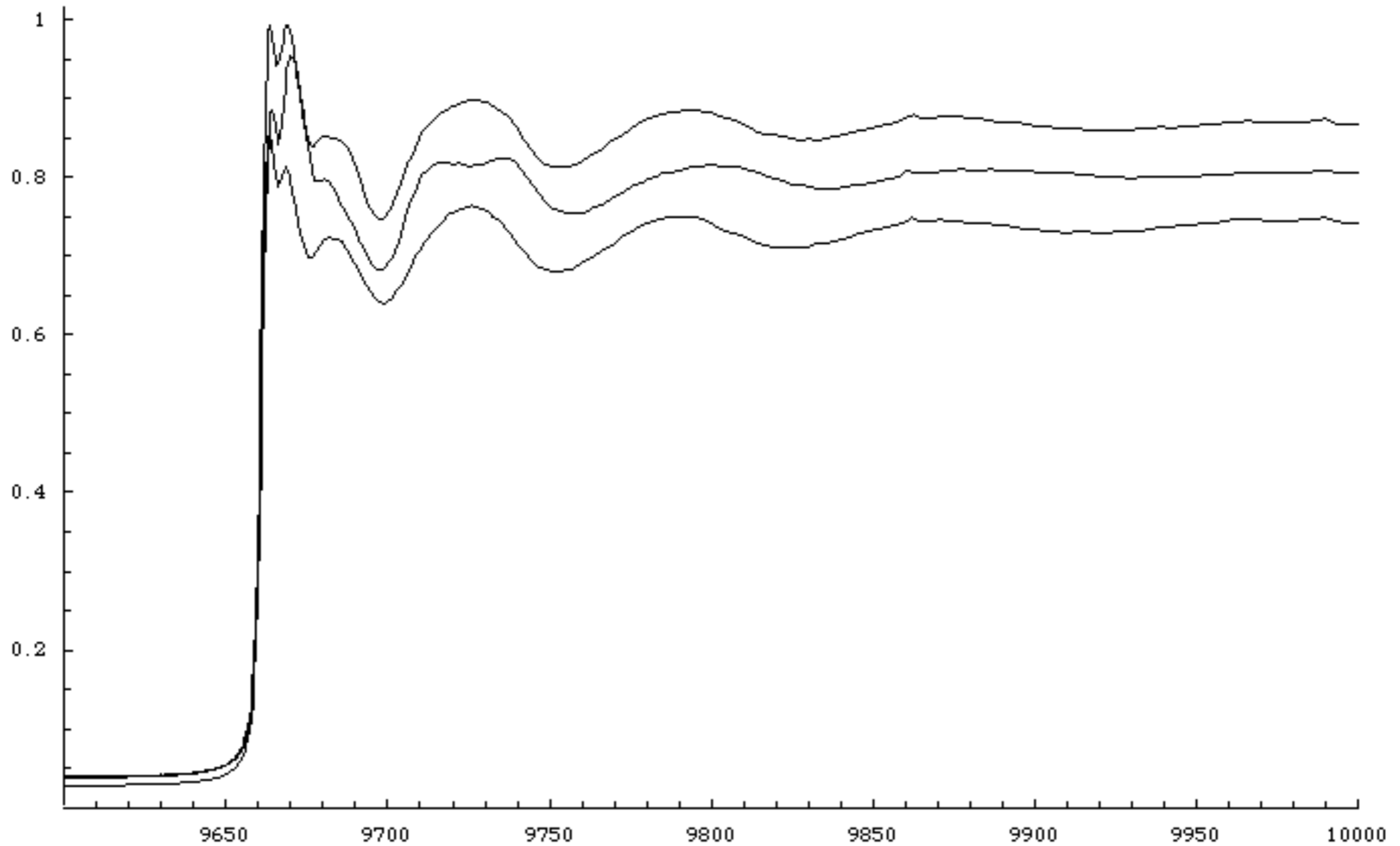

Koch models: spectra courtesy of J. Penner-Hahn

MnO
rock salt
structure
T=80K

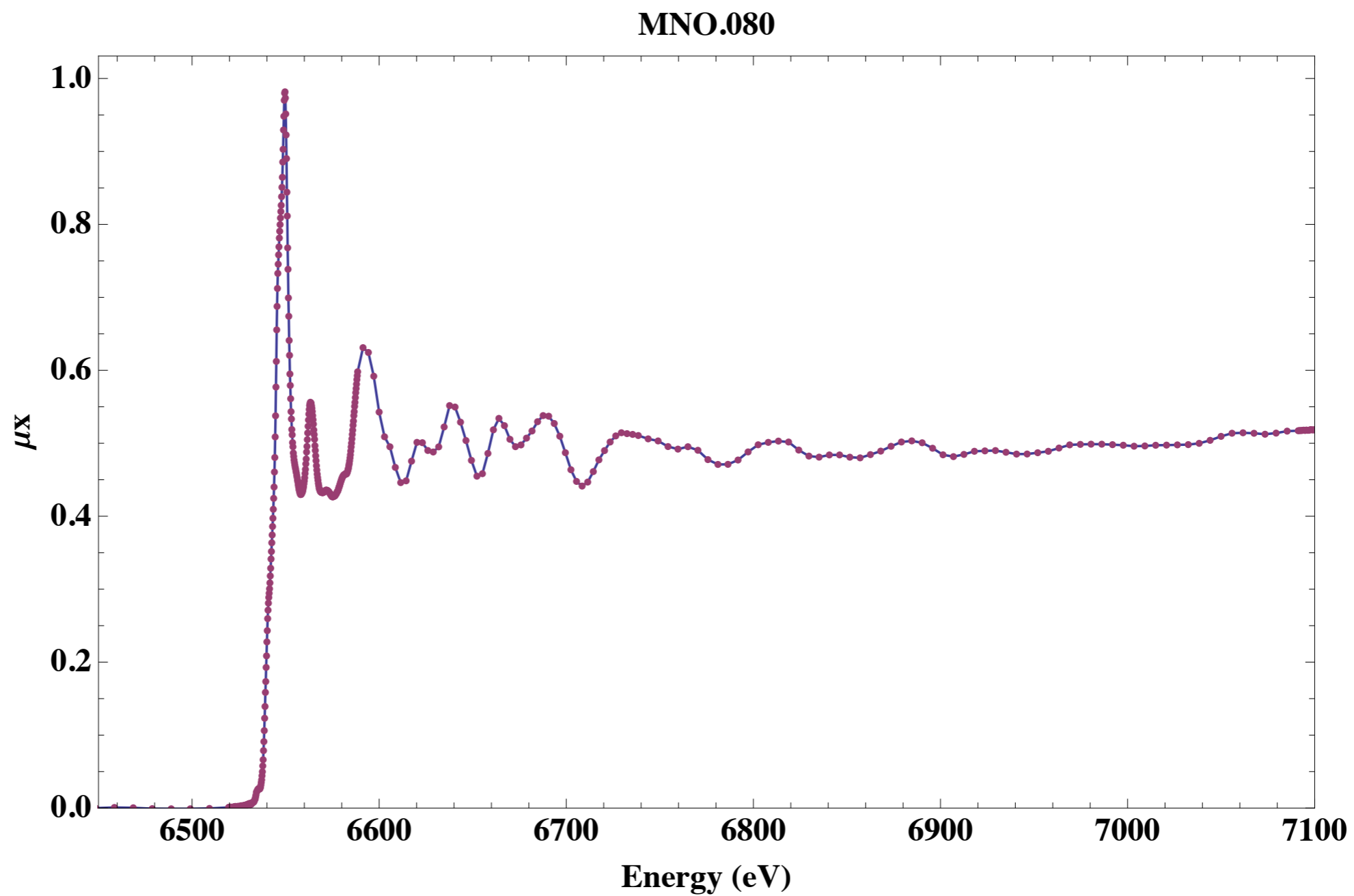

XAFS is element selective

By choosing the energy of excitation you can “tune into” different elements in a complex sample.

K-edge:

Ca: 4.0 keV

Fe: 7.1 keV

Zn: 9.7 keV

Mo: 20.0 keV

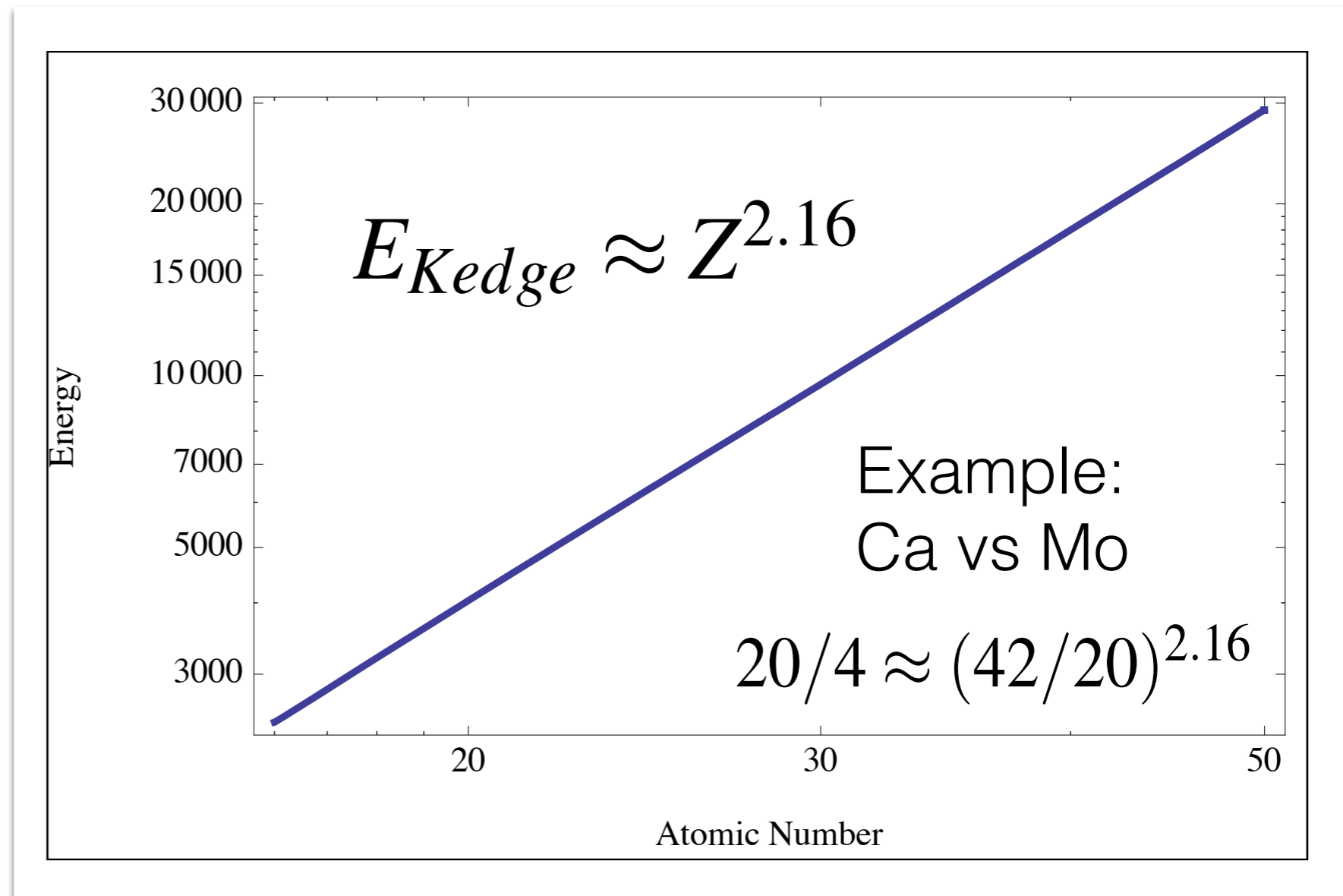

It is usually feasible to work in a convenient energy range by choosing an appropriate edge

X-ray Absorption Process

X-ray photon causes transition from $n=1$, $l=0$ ($1S$) initial state to unfilled p -symmetry ($l=1$) final state.

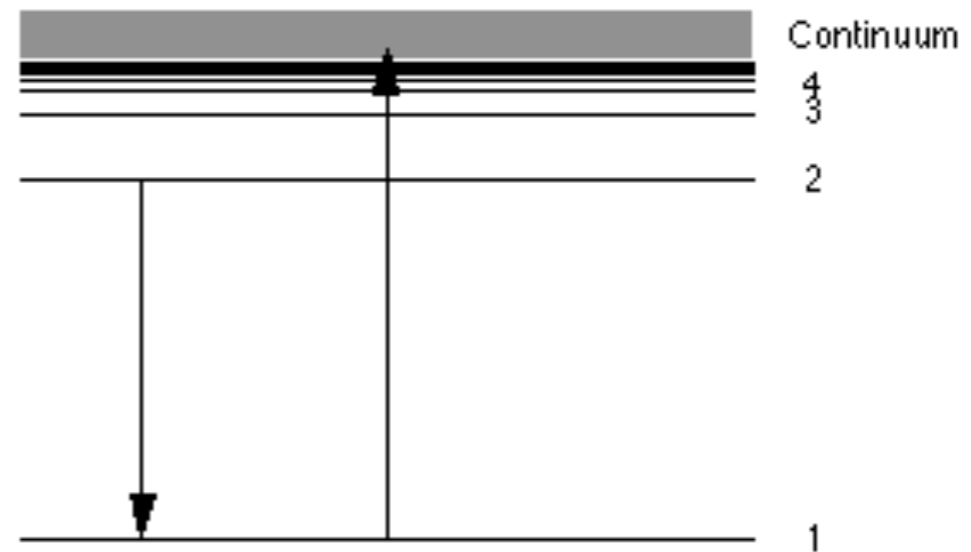

Absorption probability depends on dipole matrix element between initial and final quantum states of the electron, which are determined by local structure

$$|\langle \psi_f | \hat{\epsilon} \cdot \vec{r} e^{i\vec{k} \cdot \vec{r}} | \psi_i \rangle|^2$$

Electron waves

- X-ray photon causes transition from inner level to unfilled final state of appropriate symmetry
- If photon energy exceeds binding energy E_0 , electron has positive kinetic energy and propagates as spherical wave

$$k = \frac{2\pi}{\lambda} = \sqrt{\frac{2m}{\hbar^2} (E - E_0)}$$

Electron wave emitted by central atom is scattered by neighboring atoms. The outgoing and scattered parts of the final state wavefunction interfere where the initial state is localized.

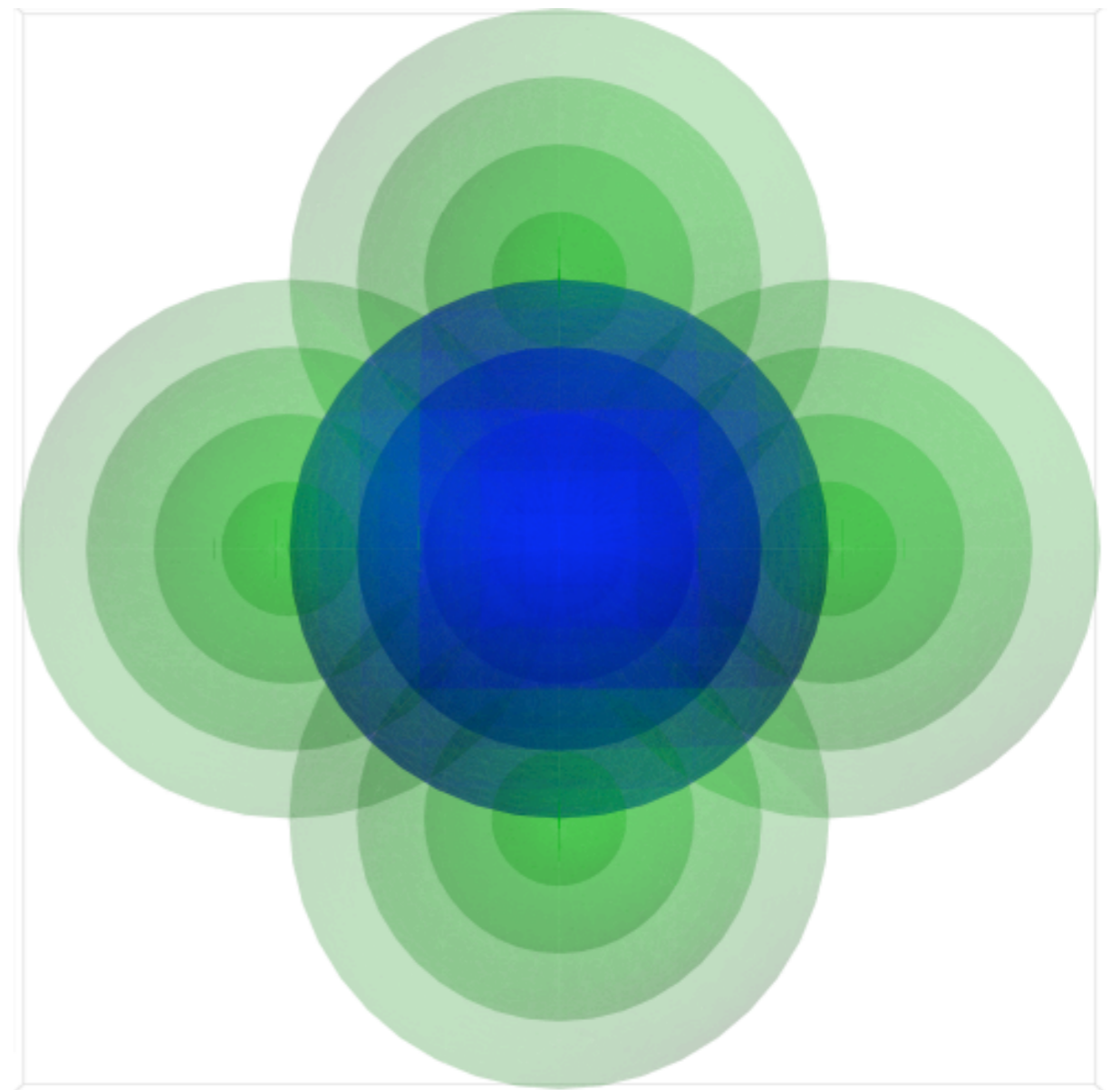

Interference is constructive or destructive depending on the distances and electron wavelength. Scanning the wavelength records an *interferogram* of distance distribution

Outgoing p-symmetry electron wave no scatterers (animation)

*Isolated atom has no final
state wavefunction
interferences.*

*Absorption coefficient
varies smoothly with
electron wavelength.*

*This directionality
can be useful for
polarized XAFS.*

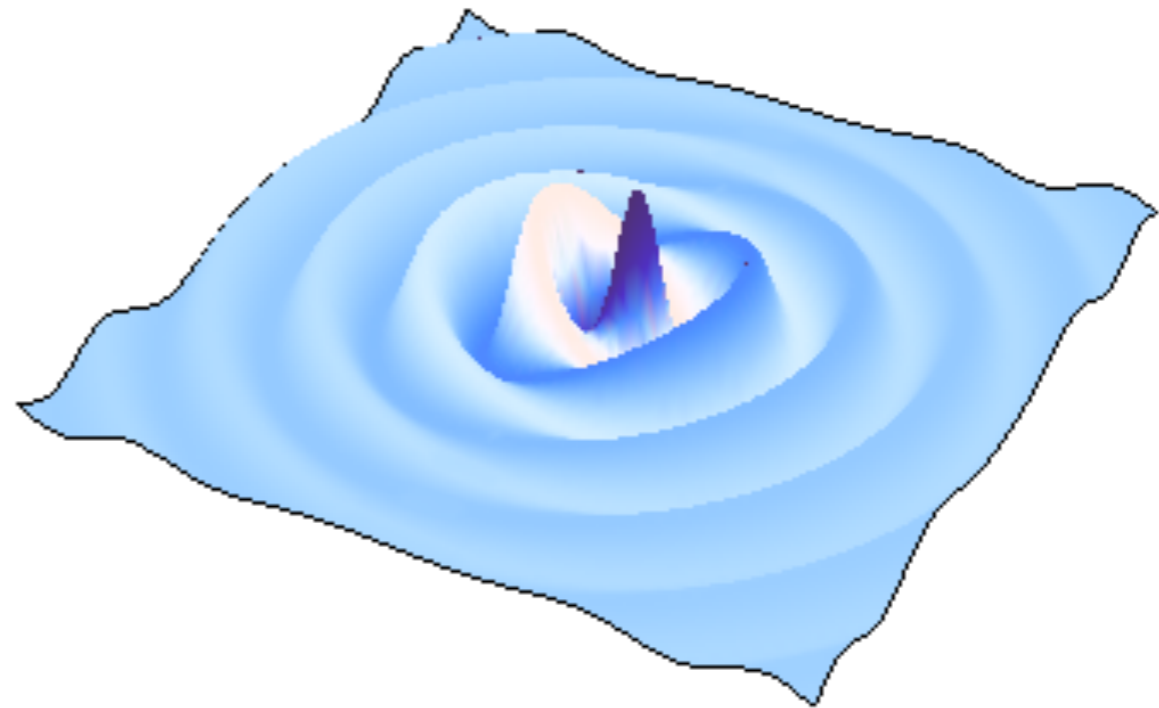

Outgoing electron wave, with scatterers (animation)

*Scattering from
neighboring atoms
modifies wavefunction
near center of absorber,
modulating the energy
dependence of the
transition matrix element*

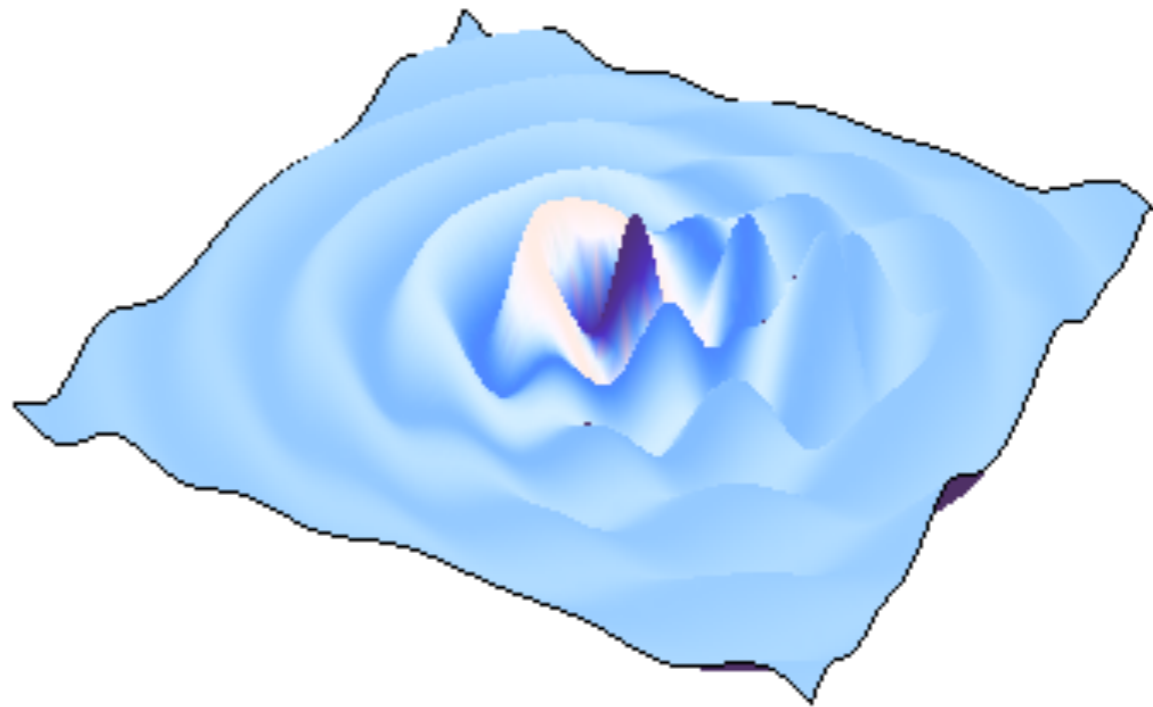

- The measured spectrum is an ensemble average of the “snapshot” spectra ($\sim 10^{-15}$ sec) of all the atoms of the selected type that are probed by the x-ray beam
- In general, XAFS determines the statistical properties of the distribution of atoms relative to the central absorbers. In the case of single scattering the pair correlation function is probed. Multiple scattering gives information on higher order correlations. This information is encoded in the chi function:

$$\mu(E) = \mu_0(E)(1 + \chi(E)); \quad \chi(E) = \frac{\mu(E) - \mu_0(E)}{\mu_0(E)}$$

EXAFS oscillations

$$\mu(E) = \mu_0(E)(1 + \chi(E)); \quad \chi(E) = \frac{\mu(E) - \mu_0(E)}{\mu_0(E)}$$

- Modulations in chi encode information about the local structure
- chi function represents the fractional change in the absorption coefficient that is due to the presence of neighboring atoms

XAFS spectroscopy provides:

- Precise local structural information (distances, numbers of atoms, types, disorder) in crystalline or noncrystalline systems e.g. metalloprotein active sites, liquids, amorphous materials
- All atoms of selected type are visible - there are no spectroscopically silent atoms for XAFS
- Information on charge state, orbital occupancy may be available by studying XANES depending on system and edge
- in situ experiments, under conditions similar to natural state, as well as crystals.
- XAFS probes effects of arbitrary experimental conditions on sample (high pressure, low temperature, pH, redox state, pump-probe, T-jump, p-jump...)
- Oriented samples provide more angular information

Complementary Structure Probes

- X-ray and Neutron diffraction
 - powerful and fast (x-ray), need good crystals, no solutions
- 2-D and higher dimensional NMR
 - Atomic resolution structures in solution, no large molecules, slow
- X-ray scattering
 - SAXS gives only low resolution information
 - wide angle can be informative
 - PDF (pair distribution function)
- XAFS
 - Gives short range structure around metal atom. Not generally sensitive or fast. XANES probes orbital matrix elements and occupancy.

Related techniques

- XMCD: X-ray Magnetic Circular Dichroism uses circularly polarized x-rays to probe magnetic structure
- IXS: Inelastic X-ray Scattering analyzes the fluorescence radiation at high resolution, providing a 2-D excitation map. Provides a great deal of information in the near-edge region
- X-ray Raman: essentially allows one to obtain XAFS-like information using high energy x-rays
- DAFS: hybrid diffraction/XAFS gives sensitivity to inequivalent sites in crystals and multilayers
- XPS, ARPEFS, fluorescence holography...

Time Dependent Perturbation Theory

Fermi's "Golden Rule" (Dirac)

Transition matrix element

$$\mu \propto \left| \int \psi_f^* \hat{\epsilon} \cdot \vec{r} e^{i\vec{k} \cdot \vec{r}} \psi_i d^3r \right|^2$$

dipole and quadrupole terms



$$\approx \left| \int \psi_f^* (\hat{\epsilon} \cdot \vec{r} + i(\hat{\epsilon} \cdot \vec{r})(\vec{k} \cdot \vec{r})) \psi_i d^3r \right|^2$$

Matrix element projects out the part of the final state that is of right symmetry (e.g p-symmetry for K-edge & dipole selection rules)

Selection rules (LS coupling)

Selection rules for discrete transitions

	Electric dipole (E1) ("allowed")	Magnetic dipole (M1) ("forbidden")	Electric quadrupole (E2) ("forbidden")
--	-------------------------------------	---------------------------------------	---

Rigorous rules	1.	$\Delta J = 0, \pm 1$ (except $0 \not\leftrightarrow 0$)	$\Delta J = 0, \pm 1$ (except $0 \not\leftrightarrow 0$)	$\Delta J = 0, \pm 1, \pm 2$ (except $0 \not\leftrightarrow 0,$ $1/2 \not\leftrightarrow 1/2, 0 \not\leftrightarrow 1$)
	2.	$\Delta M = 0, \pm 1$ (except $0 \not\leftrightarrow 0$ when $\Delta J = 0$)	$\Delta M = 0, \pm 1$ (except $0 \not\leftrightarrow 0$ when $\Delta J = 0$)	$\Delta M = 0, \pm 1, \pm 2$

	3.	Parity change	No parity change	No parity change
--	----	---------------	------------------	------------------

With negligible configuration interaction	4.	One electron jumping, with $\Delta l = \pm 1,$ Δn arbitrary	No change in electron configuration; i.e., for all electrons, $\Delta l = 0,$ $\Delta n = 0$	No change in electron configuration; <i>or</i> one electron jumping with $\Delta l = 0, \pm 2, \Delta n$ arbitrary
---	----	--	---	--

For <i>LS</i> coupling only	5.	$\Delta S = 0$	$\Delta S = 0$	$\Delta S = 0$
	6.	$\Delta L = 0, \pm 1$ (except $0 \not\leftrightarrow 0$)	$\Delta L = 0$ $\Delta J = \pm 1$	$\Delta L = 0, \pm 1, \pm 2$ (except $0 \not\leftrightarrow 0, 0 \not\leftrightarrow 1$)

Final state symmetry

- K-edge: 1s initial state ($n=1, l=0, m=0$)
- L1-edge: 2s initial state ($n=2, l=0, m=0$)
- L2-edge: 2p ($j=1/2$) initial state ($n=2, l=1$)
- L3-edge: 2p ($j=3/2$) initial state ($n=2, l=1$)
- dipole selection rules project out specific symmetry components of final state wavefunction
 - K, L1 edges probe p part of final states
 - L2,3 edges probe d (& s) part of final states

Single Scattering EXAFS Equation

Stern, Sayers, Lytle

$$\chi(k) = S_0^2 \sum_i \frac{N_j}{kR_j^2} |f_j(k; r)| e^{-2k^2\sigma_j^2} e^{-2R_j/\lambda(k)} \sin(2kR_j + \delta_j(k; r))$$

Experimental data are fit using the EXAFS equation with theoretically calculated (or empirically measured) scattering functions to determine structural parameters.

The k-dependence of scattering amplitudes and phases helps distinguish types of backscatterers

This equation is a bit too simple {large disorder, multiple scattering [focussing effect]}, but it can be generalized.

k-dependence of scattering amplitudes helps identify scatterers

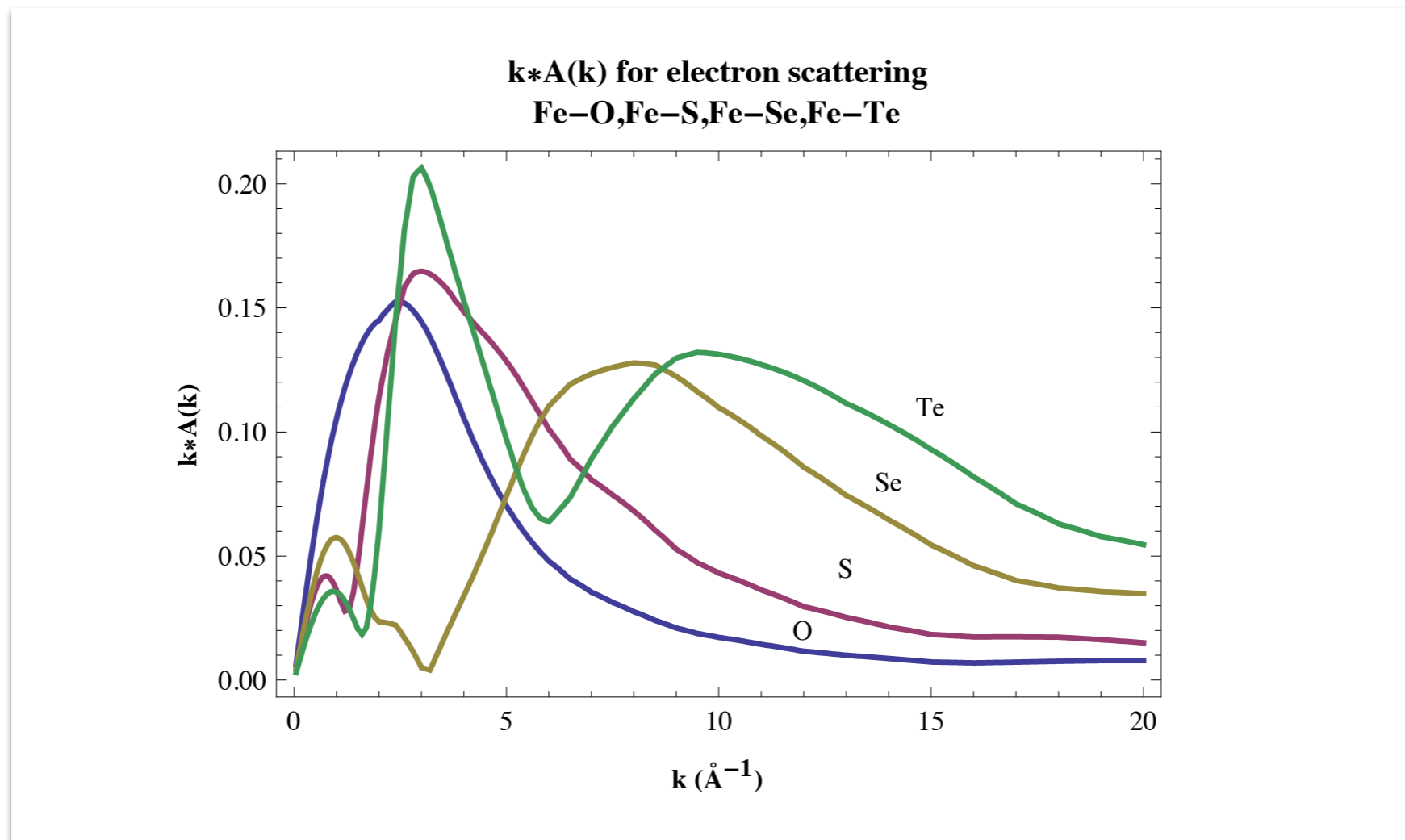

Simple example: Fx Fe-S protein from PS I

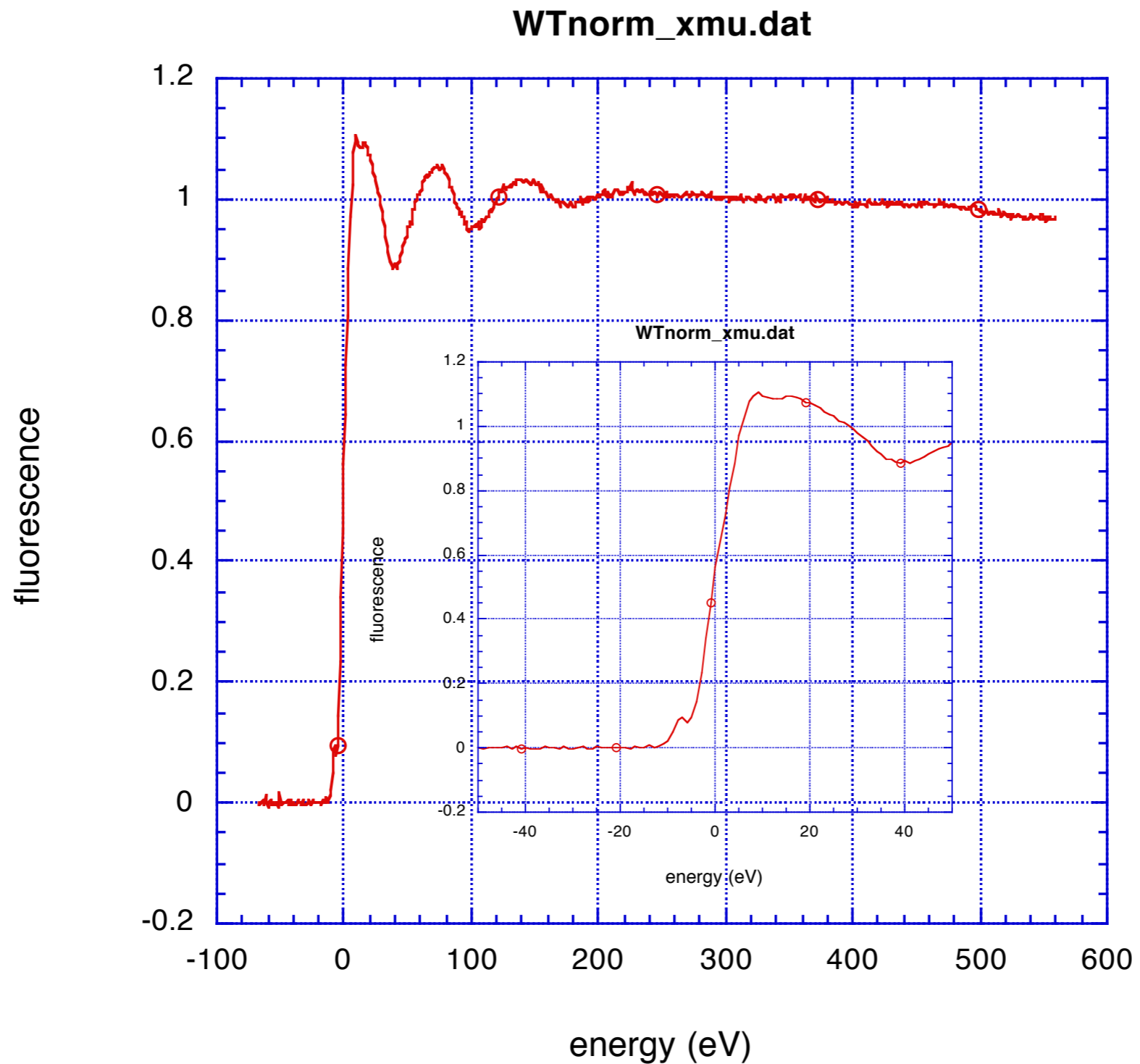

Structure of Fe-S cluster in Fx from Photosystem I

XAFS fits for 4 Fe- 4 S cluster

Fe-S N= 4.00 R=2.27(2) SS= 0.007(1)

Fe-Fe N= 3.00 R=2.68(2) SS= 0.007(1)

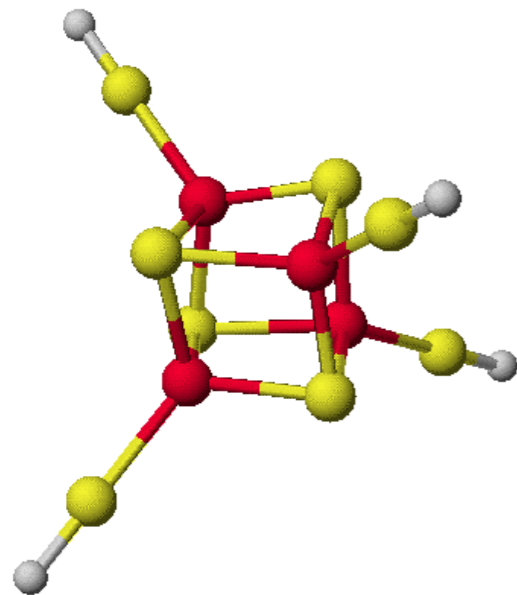

The figure shows a molecular model based on XAFS that is consistent with the determined distances. These require a distortion of the cubane-like box.

Bunker and Carmeli, 2002

Protein solution only - no crystals!

Single Scattering EXAFS equation

Stern, Sayers, Lytle...

The most basic form of the EXAFS equation is:

$$\chi(k) = \left\langle S_0^2 \sum_i \frac{3 \cos^2(\theta_i)}{kr_i^2} |f_i(k; r)| e^{-2r_i/\lambda(k)} \sin(2kr_i + \delta_i(k; r)) \right\rangle$$

where r_i is the distance to the i_{th} neighbor; $\langle \dots \rangle$ represents an average over all sites in the sample; λ is the electron mean free path, and S_0^2 is a loss factor; f_i and δ_i are the scattering amplitude and phase shift of atom i ; θ_i is the angle between the electric polarization vector of the x-ray beam \hat{e} and the vector \hat{r}_i from the center atom to neighboring atom i . The r -dependence of f and δ is weak.

EXAFS equation (isotropic average)

Averaging over angle and grouping atoms of the same atomic number and similar distances into “shells” we obtain:

$$\chi(k) = S_0^2 \sum_i \frac{N_j}{kR_j^2} |f_j(k; r)| e^{-2k^2\sigma_j^2} e^{-2R_j/\lambda(k)} \sin(2kR_j + \delta_j(k; r)),$$

where N_j, R_j, σ_j^2 are the coordination number, average distance, and mean square variation in distance to atoms in shell j . These are the leading terms in the “cumulant expansion”. If $k\sigma$ is not $\ll 1$, higher order terms should be considered.

EXAFS is basically a sum of damped sine waves
=> Fourier Transform, beat analysis

EXAFS DWFs are comparable to, but distinct from, diffraction DWFS.
There are both static and thermal contributions to σ^2

Multiple Scattering Expansion

Multiple scattering is accounted for by summing over MS paths Γ , each of which can be written in the form [ref: Rehr, Rev. Mod. Phys., 2000]

$$\chi_{\Gamma}(p) = S_0^2 \operatorname{Im} \left(\frac{e^{i(\rho_1 + \rho_2 + \dots + \rho_N + 2\delta_l)}}{\rho_1 \rho_2 \dots \rho_N} e^{-2p^2 \sigma_{\Gamma}^2} \times \operatorname{Tr} M_l F^N \dots F^2 F^1 \right)$$

where p is the complex photoelectron momentum, ρ_j are p times the path lengths of the i_{th} leg of the MS path Γ ; the F matrices describe the scattering from each atom in the path; M is a termination matrix.

This can be expressed similarly to SSL form

$$\chi_{\Gamma}(p) = S_0^2 \operatorname{Im} \left(\frac{f_{\text{eff}}}{kR^2} e^{2ikR + 2i\delta_l} e^{-2p^2 \sigma_{\Gamma}^2} \right)$$

whence “Feff”

Leading MS paths tetrahedral MnO4

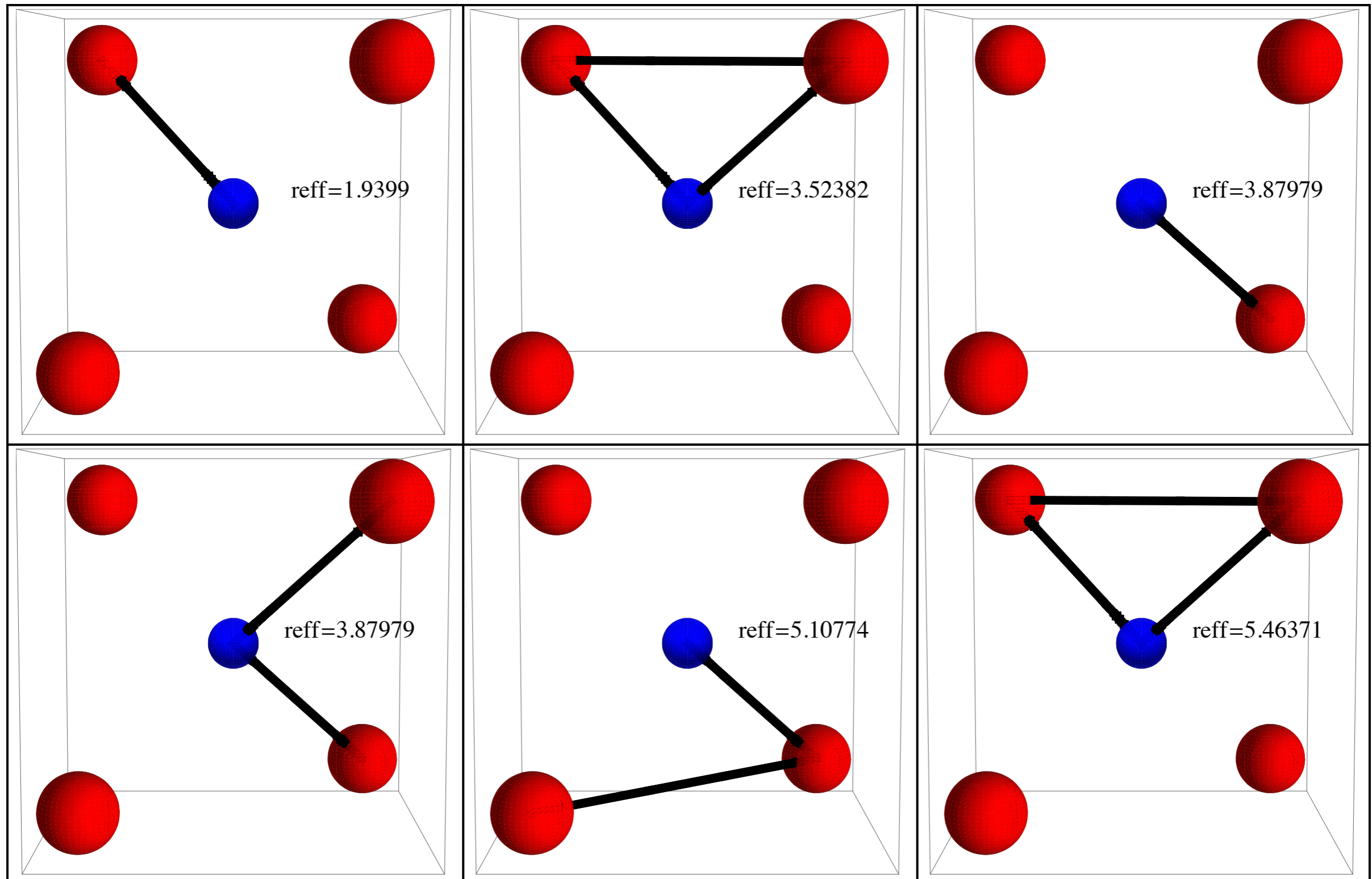

theory: MnO₄ tetrahedral cluster

$r=1.63, 1.73, 1.84, 1.94 \text{ \AA}$ $f_{\text{eff}} 8.2$ SCF/FMS

the shorter the distance,
the higher the edge energy and
the more intense the pre-edge

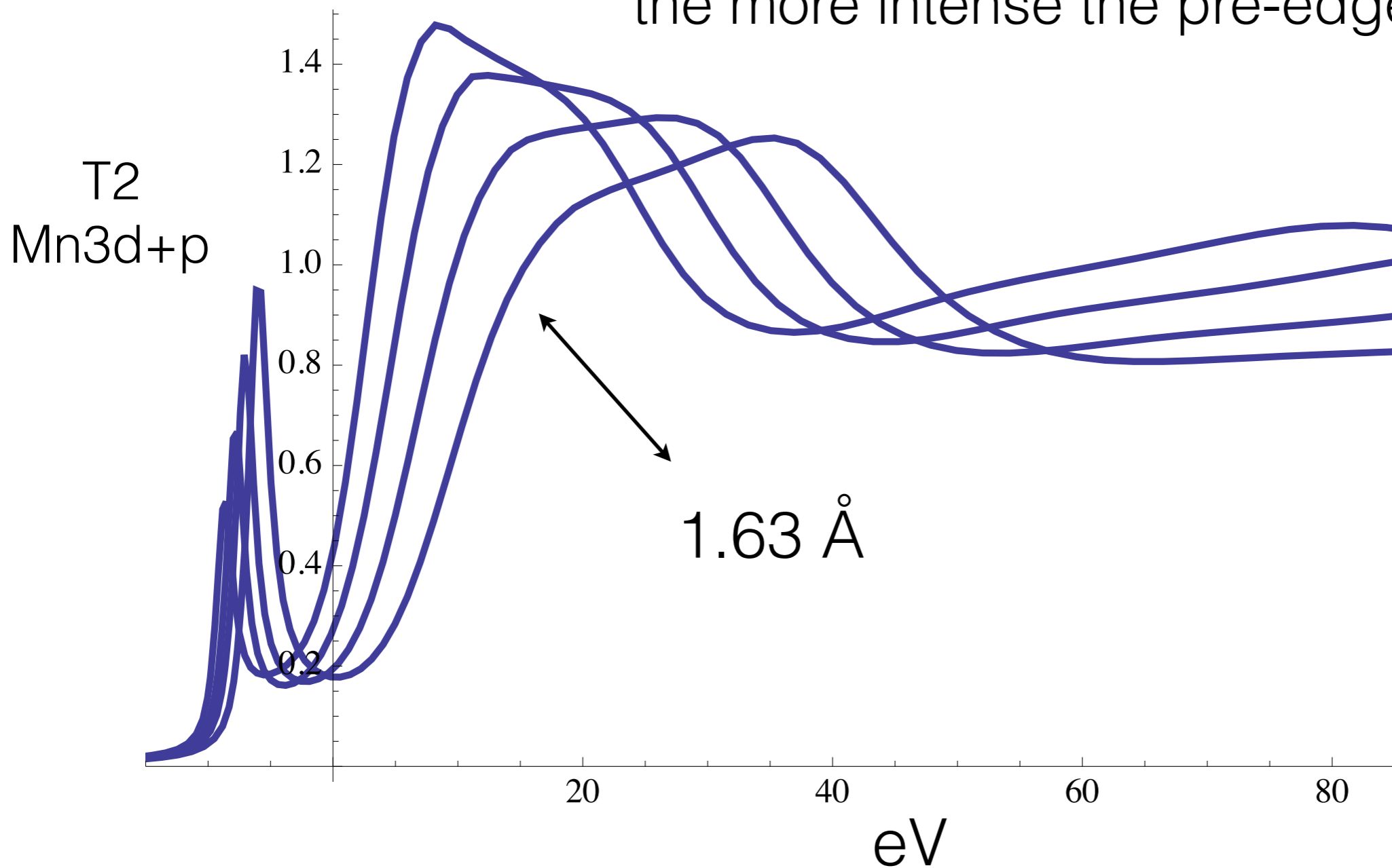

MnO4 model cluster, feff8 SCF/FMS

$r=1.63, 1.73, 1.84, 1.94\text{\AA}$

energy rescaled as $1/r^2$

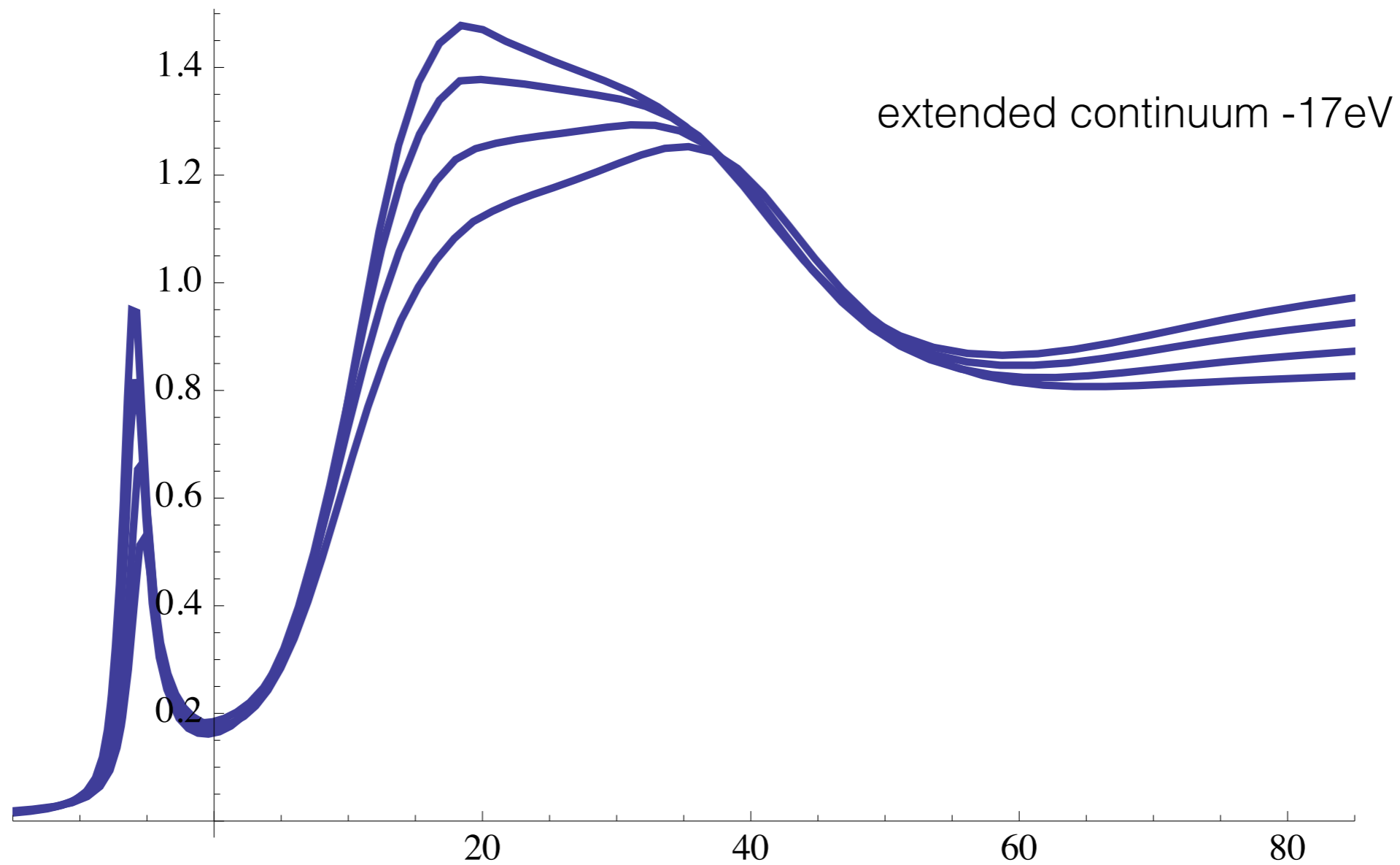

expt.

Solid KMnO₄ at 80K and 300K experimental data*

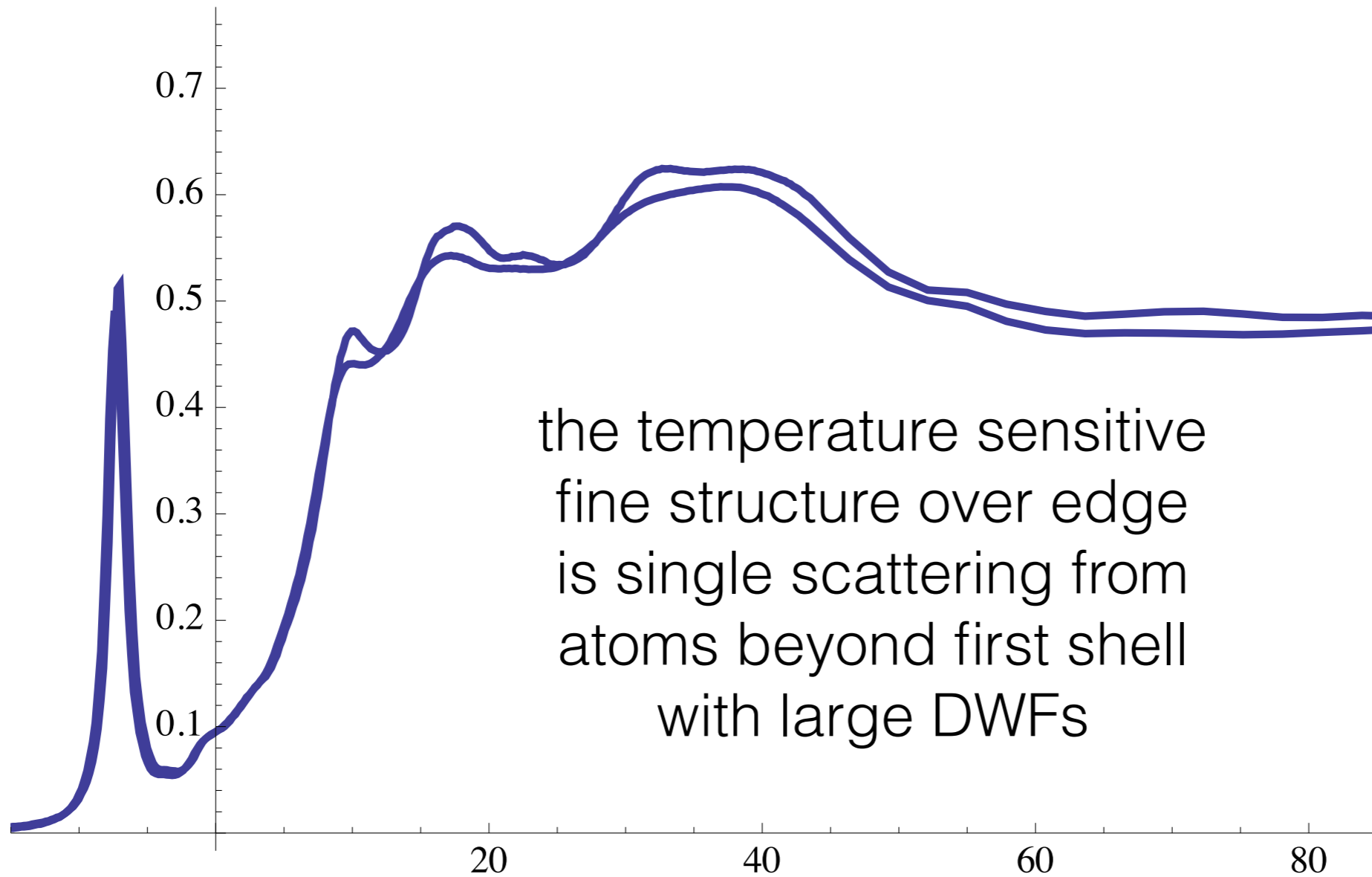

* G Bunker thesis 1984

XANES landscape is from SS+MS
among nearest neighbor tetrahedron
SS from distant atoms adds
temp dependent fine structure

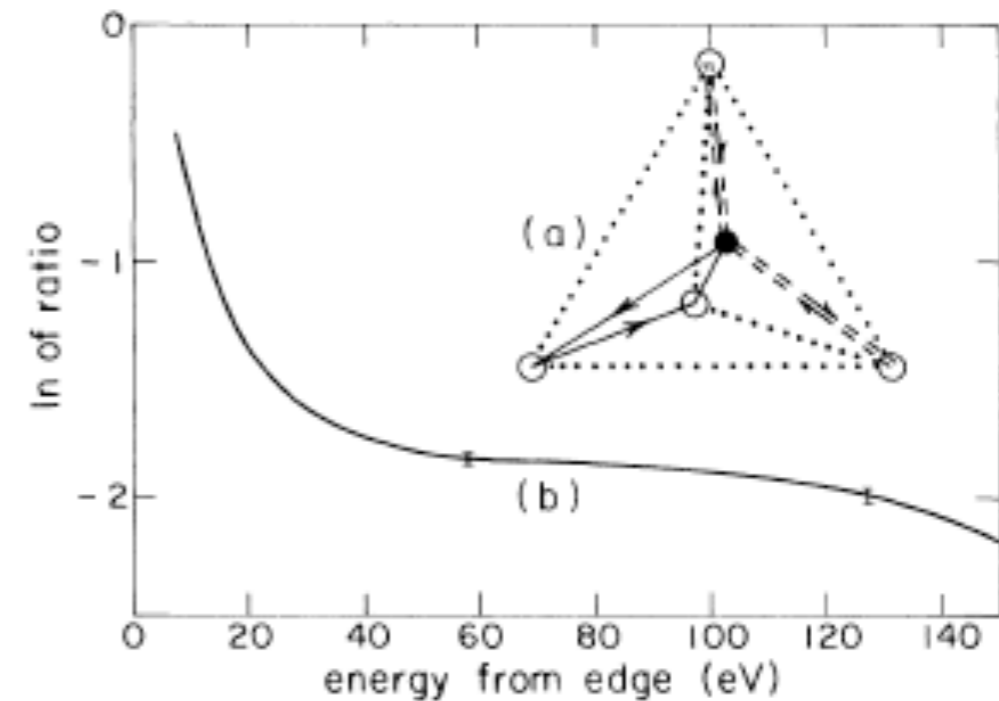
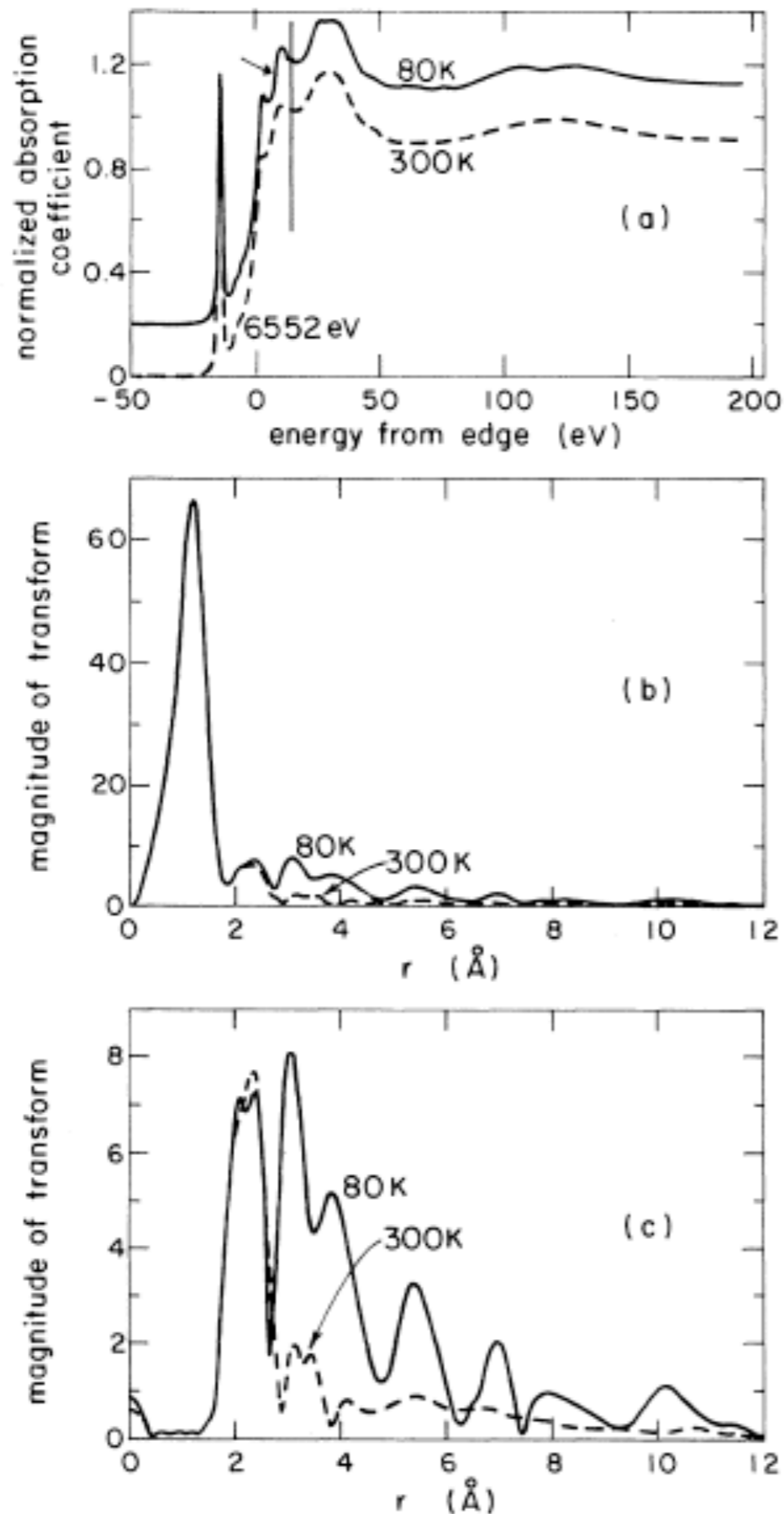

FIG. 2. (a) The two multiple-scattering paths that contribute to the second peak in the Fourier transform of KMnO_4 , denoted by solid and dashed lines. The black dot is Mn, and the open dots are O atoms. (b) The logarithm of the ratio of the k dependence of the amplitudes of the first (SS) peak to the second (MS) peak of Fig. 1(b), plotted vs energy from the edge.

XAFS experimental requirements

- suitable sample (depends on measurement mode)
- intense broad-band or scannable source
- monochromatic (~ 1 eV bandwidth), scannable beam, energy suitable for elements of interest
- suitable detectors (depends on mode)
- special equipment (cryostats, goniometers..)

Basic Beamline Components for XAFS

source

(mirror)

monochromator

(mirror)

slits

detectors

Collimating mirror is sometimes used to match source to acceptance of mono

mirror following mono is often used for harmonic rejection or focussing

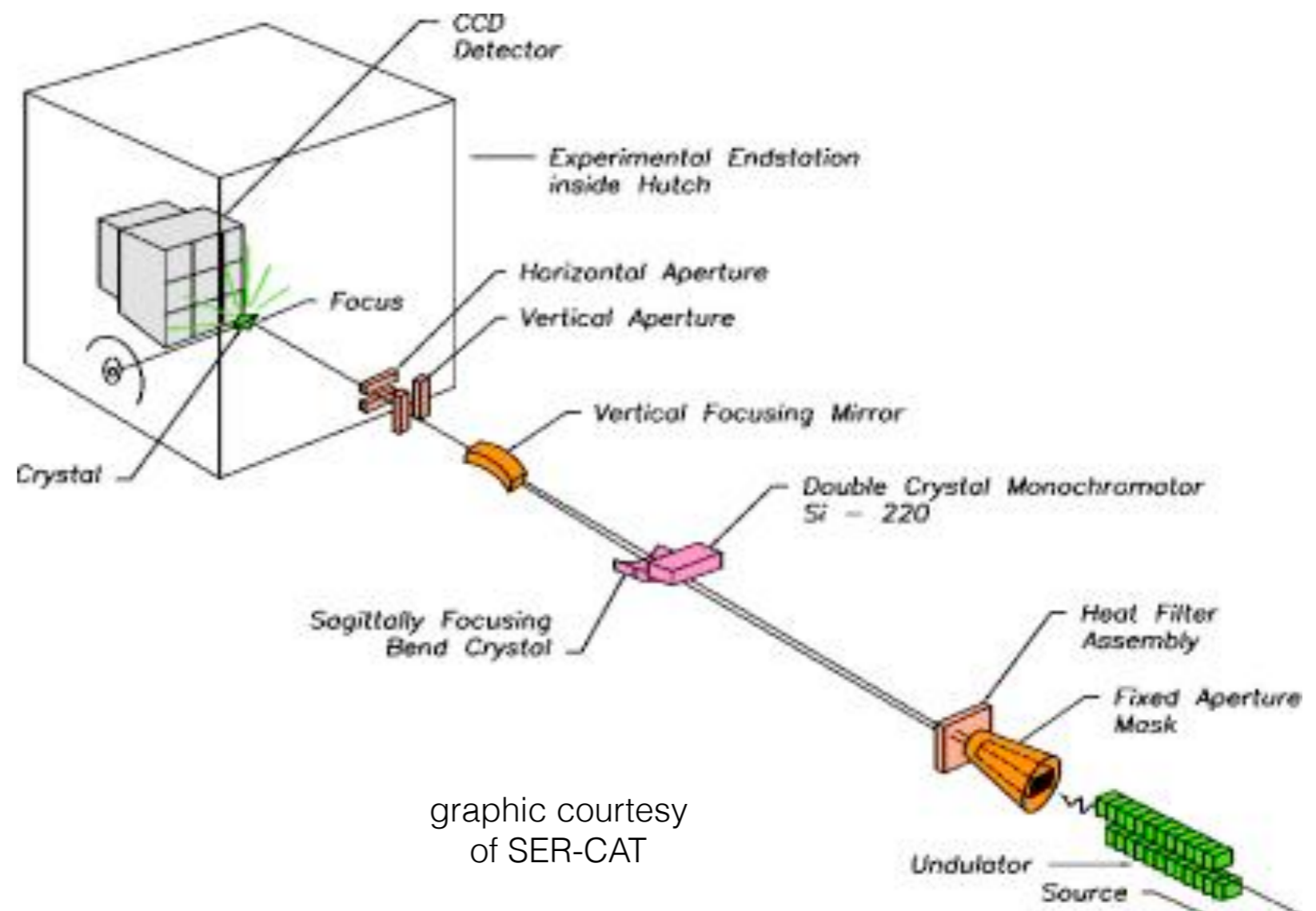

Experimental modes

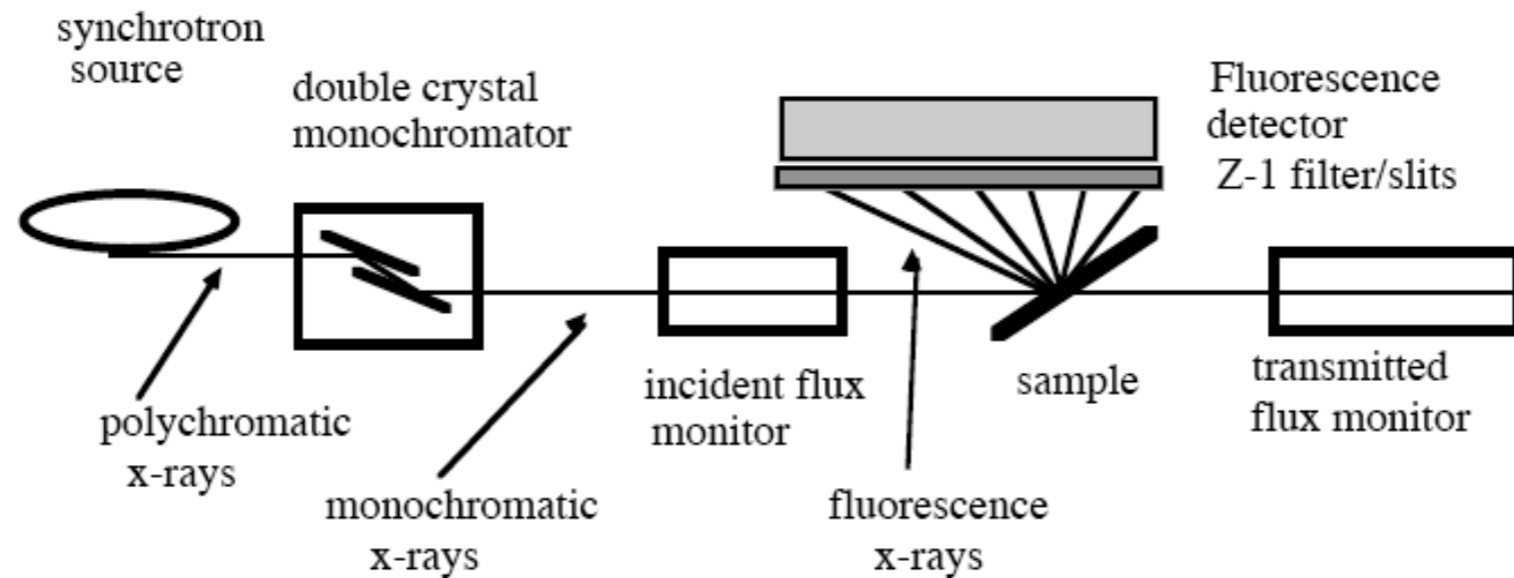

Figure 1 – Schematic XAFS experiment

Detection

- Transmission mode
- Fluorescence mode
- Electron yield
- Inelastic X-ray Scattering

Geometry

- Oriented e.g. single crystal
- Magic Angle Spinning
- Total External Reflection
- Grazing (glancing) incidence

Which mode to use?

- concentrated, not too thick: -> use transmission
want edge step ~ 1.0 (>0.1 , <2.0)
- concentrated, thick: -> use electron yield, total external reflection fluorescence, or apply fluorescence corrections numerically
- dilute samples: ($< .1$ absorption length edge step) use fluorescence detection
- microbeams can used to measure small grains which may be concentrated even if sample is dilute on average (still must worry about particle size effects though)

Checklist: “HALO” Mnemonic

- Harmonics - get rid of them using mirrors, detuning, or other means, especially for thick transmission samples.
- Alignment - the beam should only see homogeneous sample and windows between the I0 and I (or If) detectors
- Linearity - ionization chambers must be plateaued. Other detectors may need deadtime corrections
- Offsets - dark currents must be measured and subtracted to compensate for drifts

Standard EXAFS Detectors

- Integrating (non-energy resolving)
 - Ionization chambers
 - Fluorescence ionization chambers (Stern/Heald)
 - PIN diodes/PIPS detectors
- Pulse counting (energy resolving)
 - Solid State (Ge/Si) detectors
 - Silicon Drift Detectors (SDD)
 - Scintillator/Photomultiplier (PMT)
 - Proportional Counters (PC)
 - Avalanche Photodiodes (APD)

Fluorescence ion chamber

Stern/Heald/Elam + Lytle

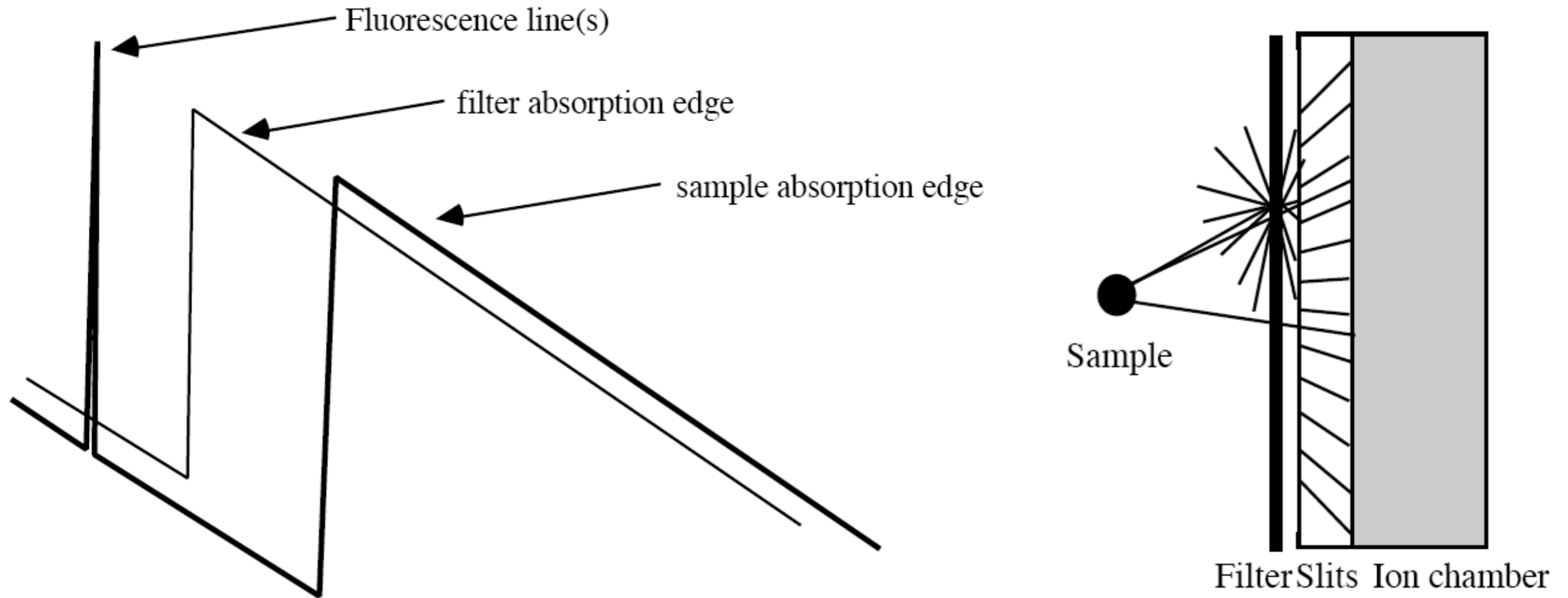

Often used with filter and soler slits to keep scattered background out of detector

“Lytle Detector”

www.exafsc.com

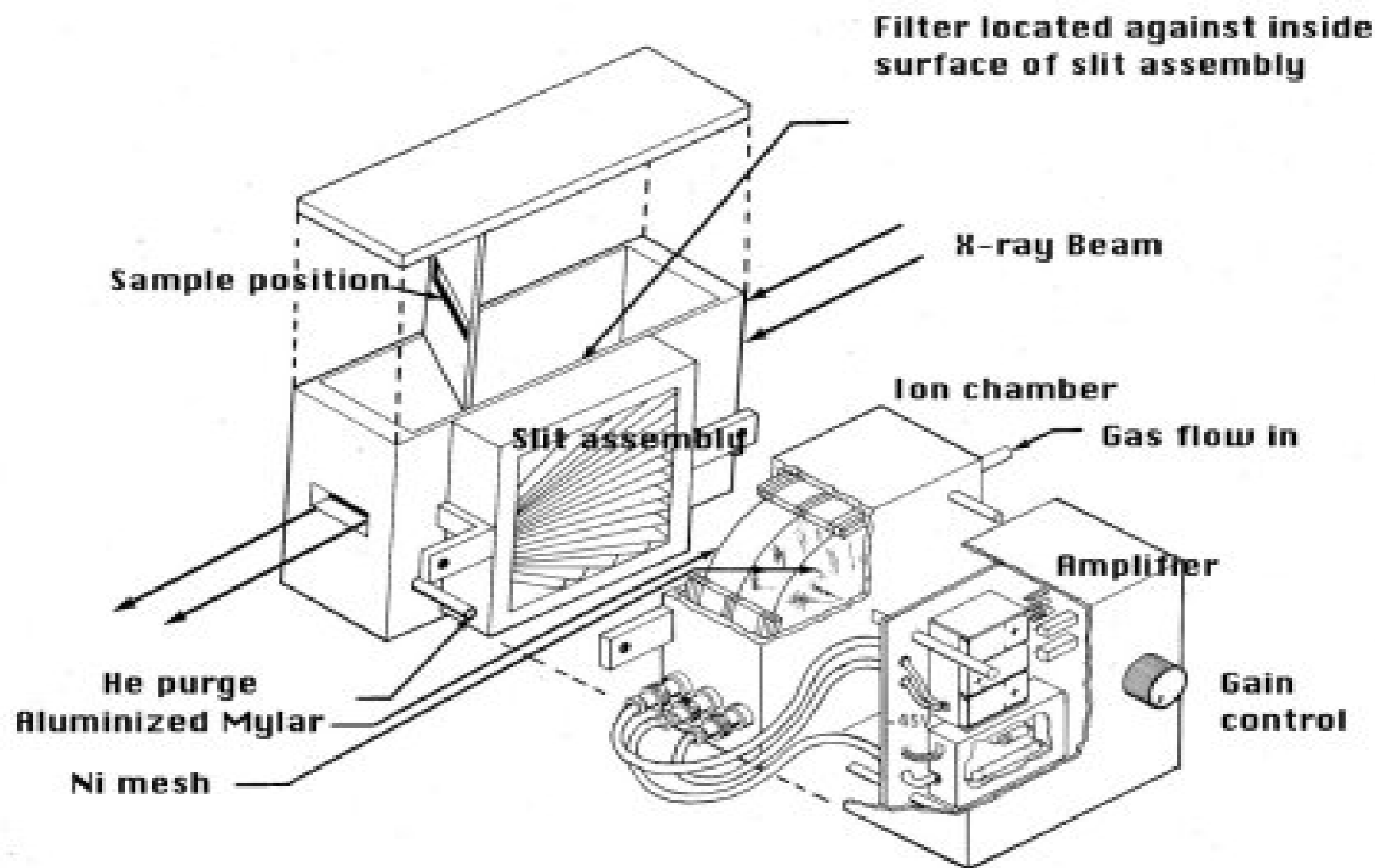

Stern/Heald/Lytle Detectors

Performance for dilute systems depends critically on filter and slit quality, and correct choice of filter thickness. This approach cannot eliminate fluorescence at lower energies.

excellent
filter and
ideal slits

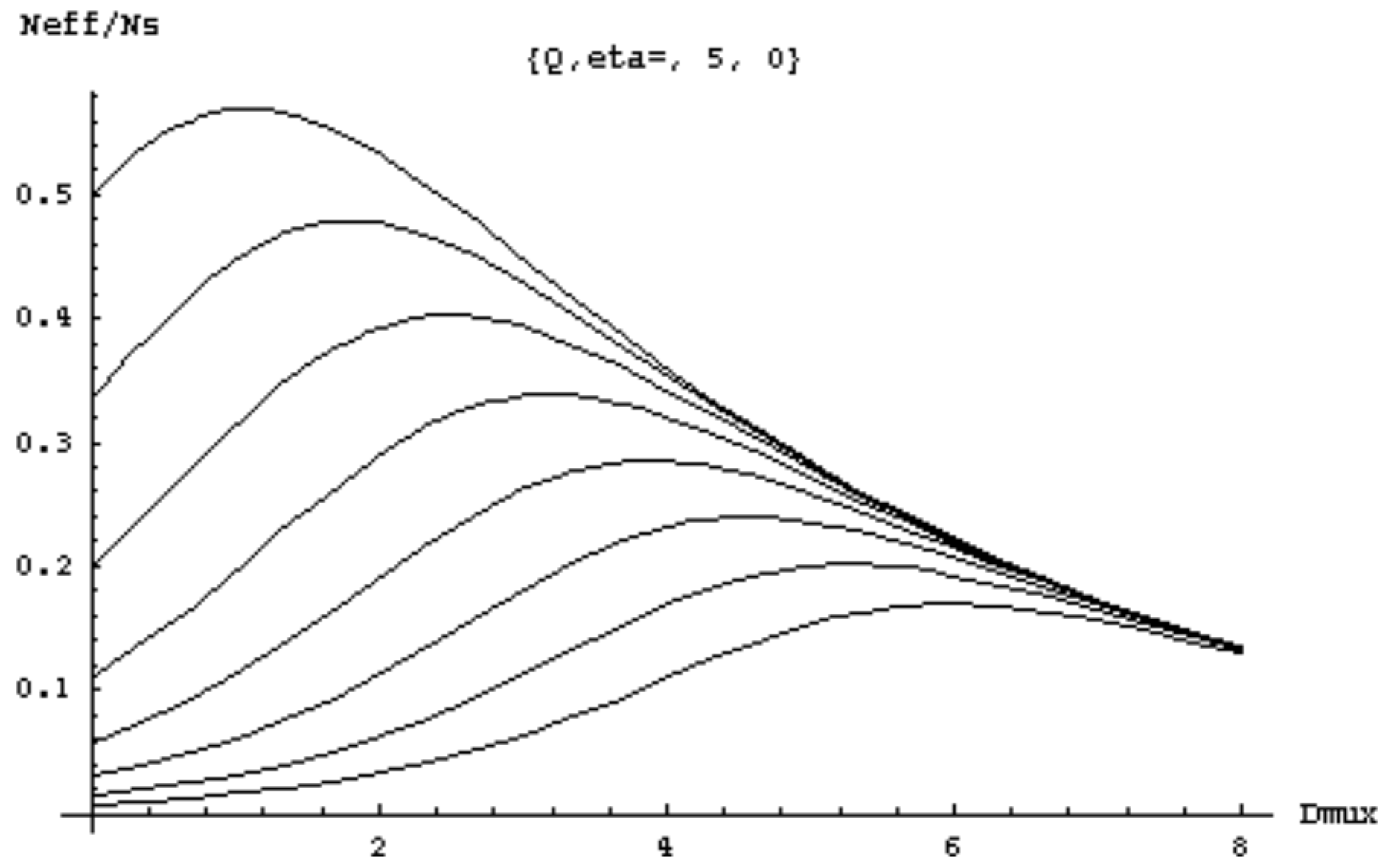

for more info see: <http://gbxafs.iit.edu/training/tutorials.html>

Stern/Heald Detector cont'd

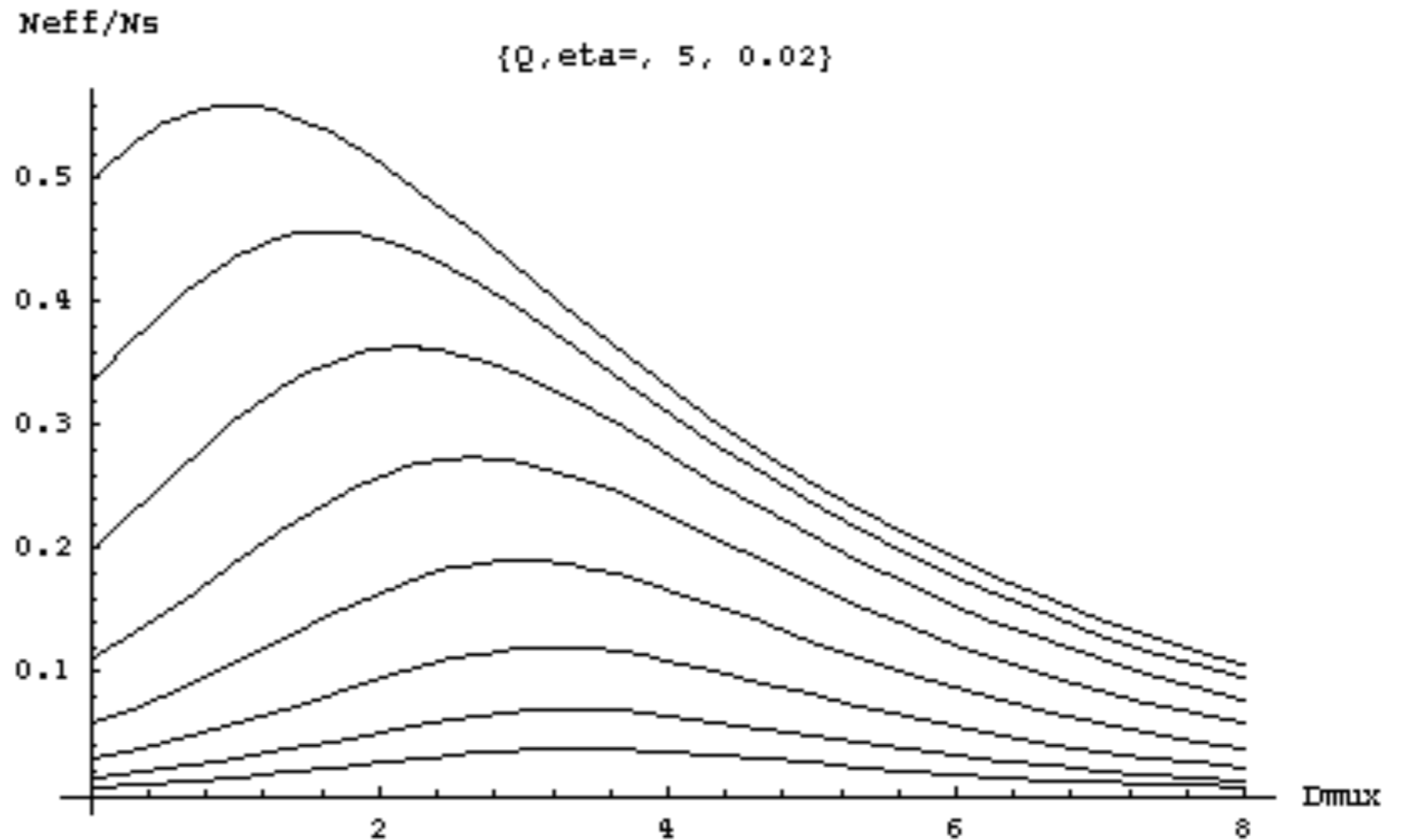

Limitations to common slit systems seriously degrade performance at high dilution

Even with optimized filters, efficiency drops to a few percent for large (>100) background to signal ratios

Multielement Germanium Detector



13 element Canberra

detector->
preamp->
shaping amp->
multichannel analyzer
or SCA & scaler

Maximum count rates of several hundred KHz total (signal +background)/channel.

Can use together with Z-1 filters and Soller slits

SDD Arrays

higher count rates are under active development

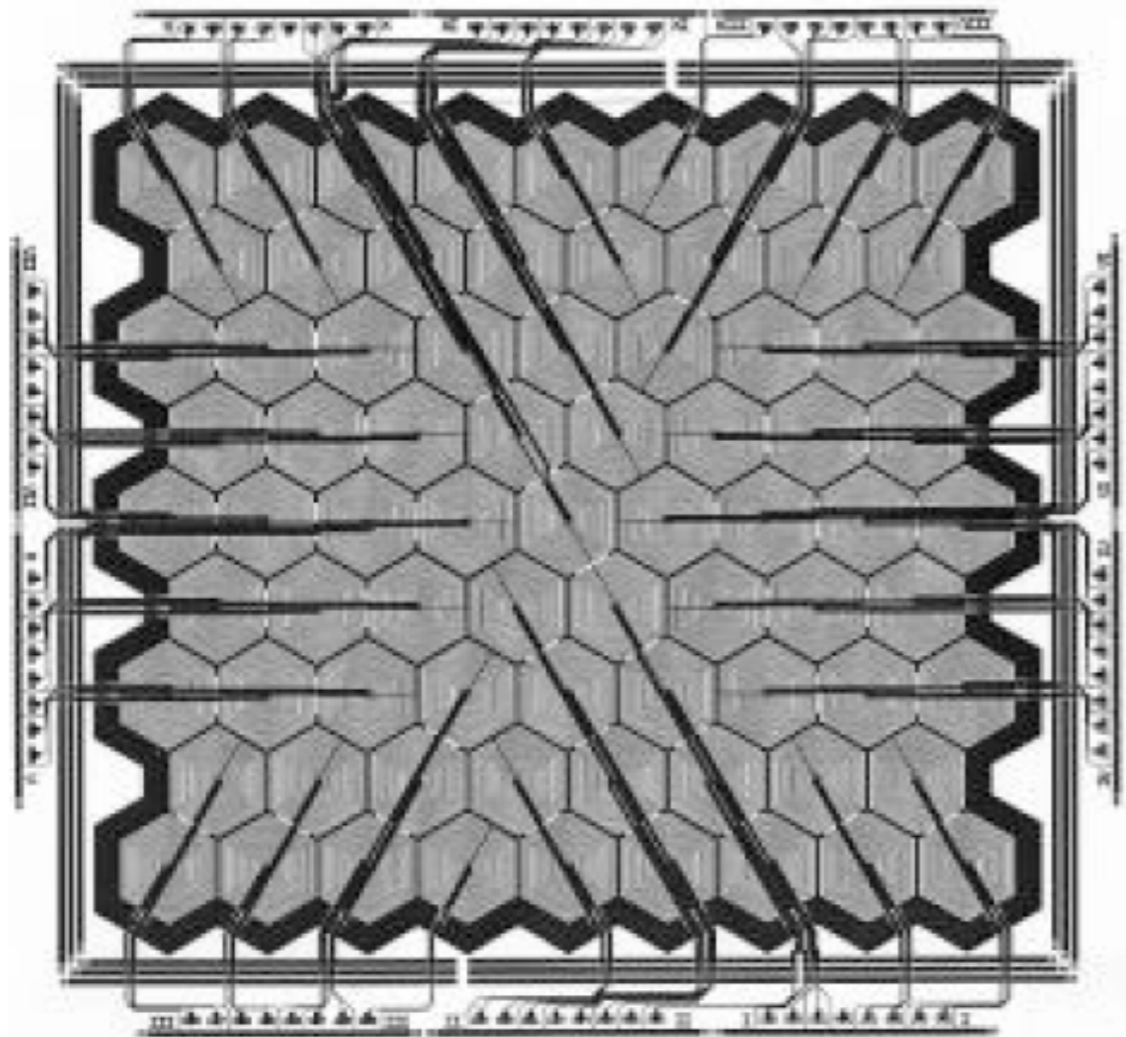

77 element prototype
silicon drift detector

C. Fiorini et al

Total active area
 6.7 cm^2

X-ray Analyzers

- Conventional solid state detectors can be easily saturated at high flux beamlines
- They spend most of their time counting background photons you throw out anyway
- Multilayer, bent crystal Laue, and other analyzers eliminate background before it gets to detector
- graphite log-spiral analyzer (Pease), Bragg log spiral analyzer (Attenkofer et al) are also good approaches
- Effectively no count rate limits, and good collection efficiency, or better resolution
- No count rate limit due to pulsed nature of source

Multilayer Array Analyzer Detector

This device uses arrays of synthetic multilayer structures to diffract the signal and eliminate scattered background. It makes possible some experiments that are otherwise intractable

Advanced versions of these analyzers are under development

www.hdtechinc.com

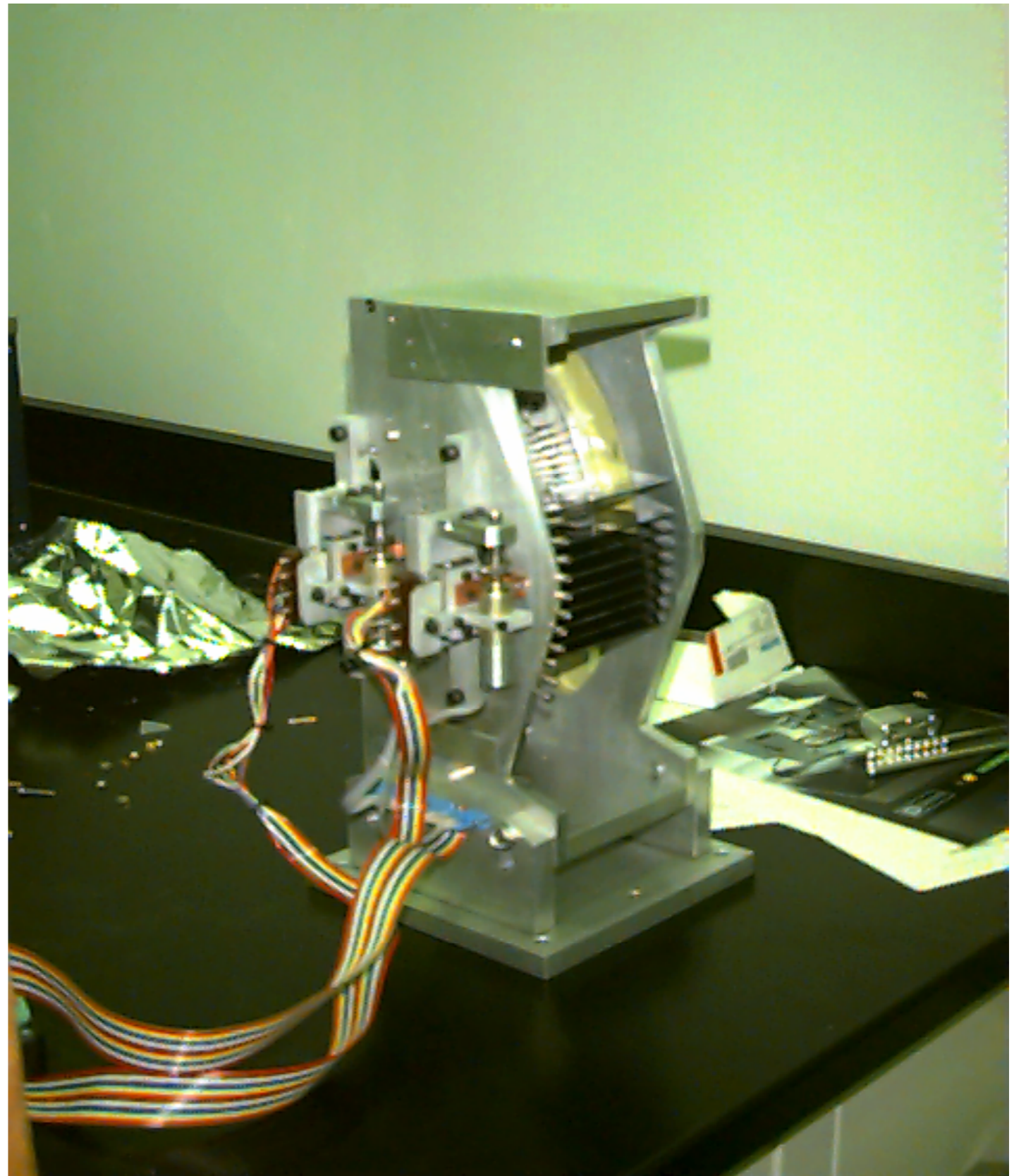

Bent Crystal Laue Analyzers

Extremely bent silicon crystals have very high efficiency and wide angular acceptance

Logarithmic spiral bent crystal

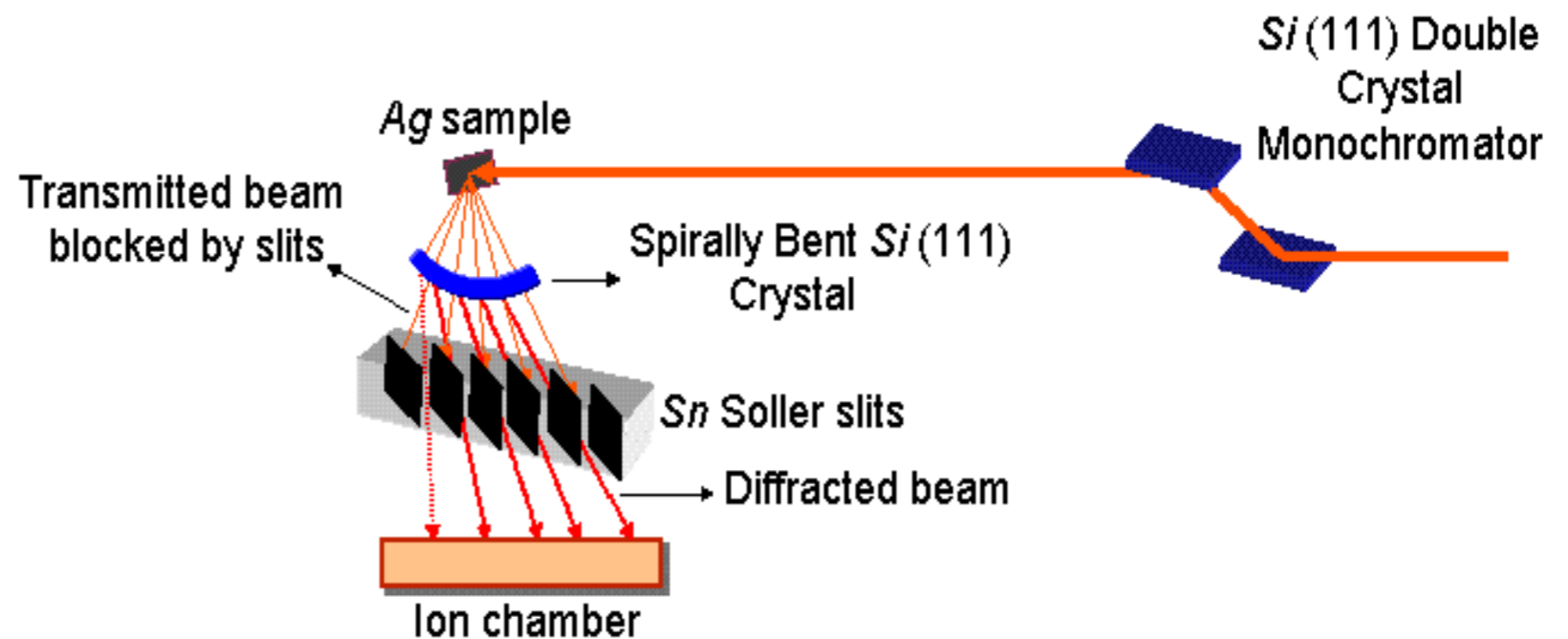

Bent Laue Analyzer

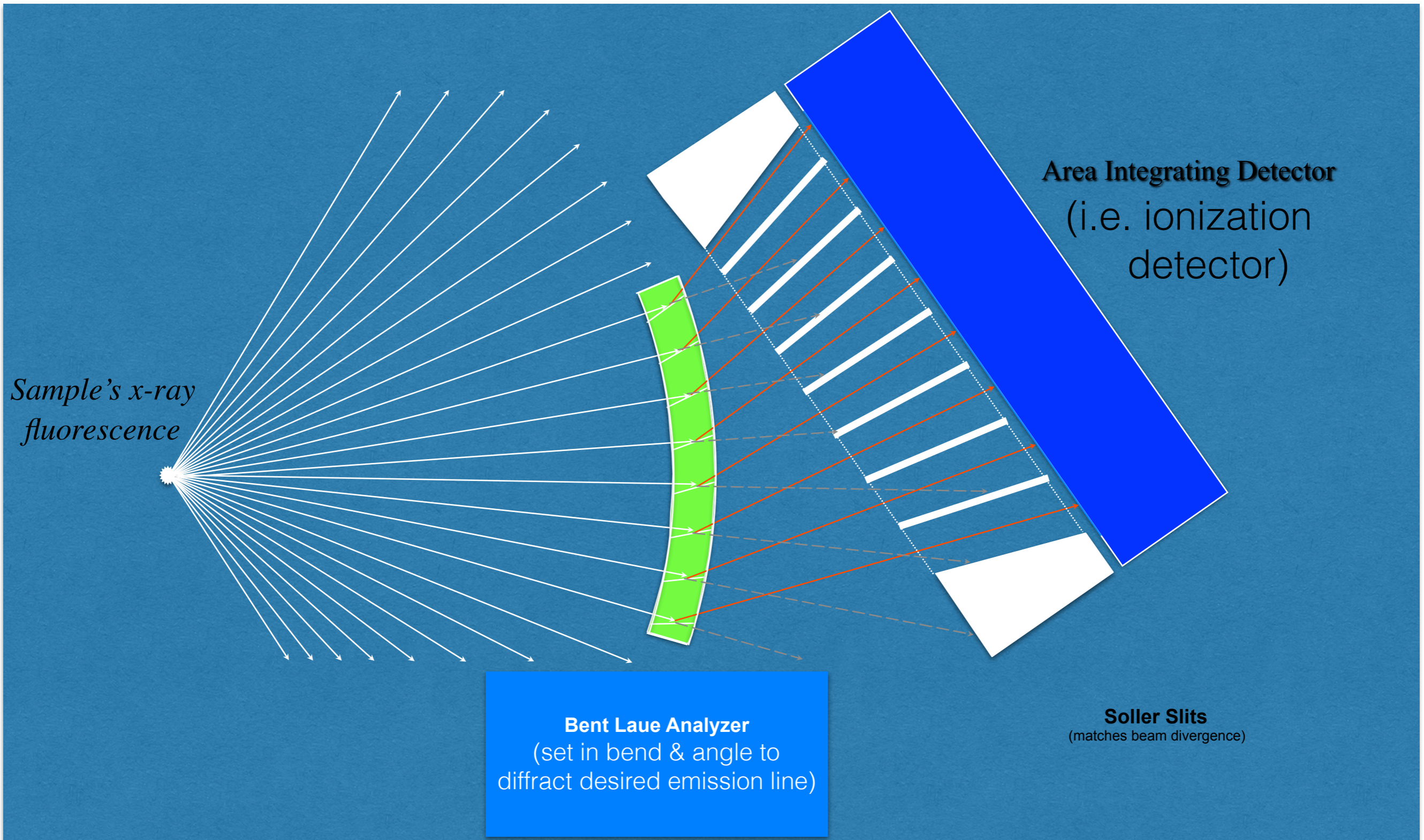

Bent Crystal Laue Analyzer

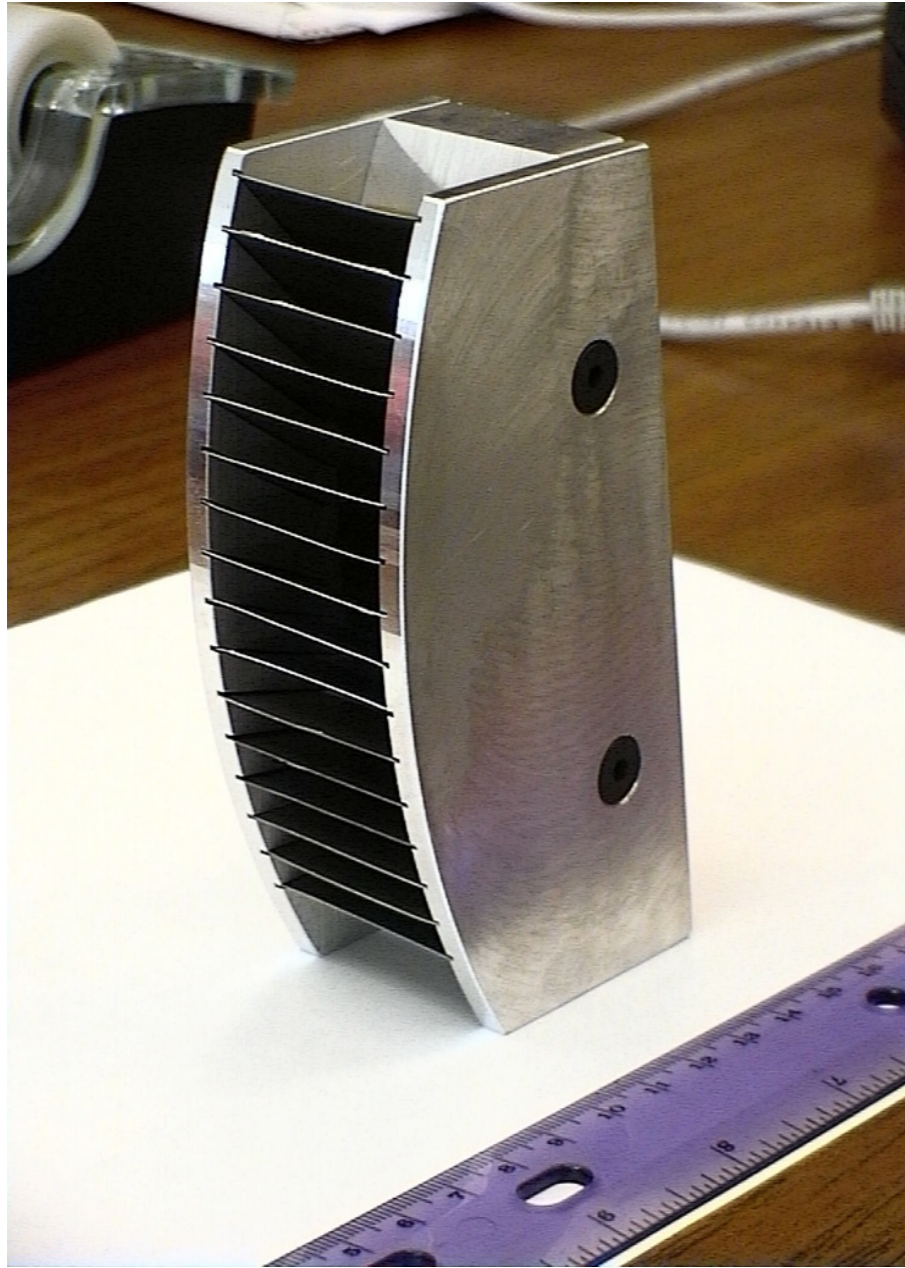

www.quercustech.com

Data Analysis

- Modern codes for calculating theoretical XAFS spectra are accurate enough to use to fit experimental data directly. “FEFF9” (J.J. Rehr et al) is a leading program for calculating spectra. Others include GNXAS and EXCURV.
- FEFF does not analyze the data for you, however. Add-on programs of various kinds (e.g. Artemis/Athena/Horae/Demeter, Larch, Sixpack, EXAFSPAK...) use (or can use) FEFF-calculated spectra to fit the data by perturbing from an initial guess structure. Parameterizing the fitting process can be simple or quite involved.
- Another approach (Dimakis & Bunker) basically uses FEFF as a subroutine and combines it with other info (e.g. DFT calculations) to estimate DWFs.

Conventional EXAFS Data Analysis

Data Reduction

- Apply instrumental Corrections (e.g. detector dead-time)
- Signal average as necessary
- Normalize data to unit edge step (compensates for sample concentration/thickness)
- Convert from $E \rightarrow k$ space (makes oscillations more uniform spatial frequency, for BKG and Fourier transform)
- Subtract background using cubic splines or other methods
- Weight data with k^n , $1 \leq n \leq 3$; (compensates for amplitude decay)
- Fourier transform to distinguish shells at different distances
- Fourier Filter to isolate shells (optional)

Data Modeling

- Fit data in k-space, r-space, or E-space using single or multiple scattering theory, and theoretical calculations (e.g. Feff9, GNXAS, EXCURV)
- Fitting is done by describing an approximate hypothetical structure in terms of a limited number of parameters, which are adjusted to give an acceptable fit.
- Good open-source software is available e.g. feff6 (Rehr), ifeffit/Artemis/Athena (Ravel/Newville), SixPack (Webb) GNXAS (Di Cicco/Filliponi), RoundMidnight(Michalowicz), EXAFSPAK (George)...
- FEFF9 must be licensed, but it's at reasonable cost.
- Other programs e.g. Mathematica, R can be useful.

Example: Raw XAFS data

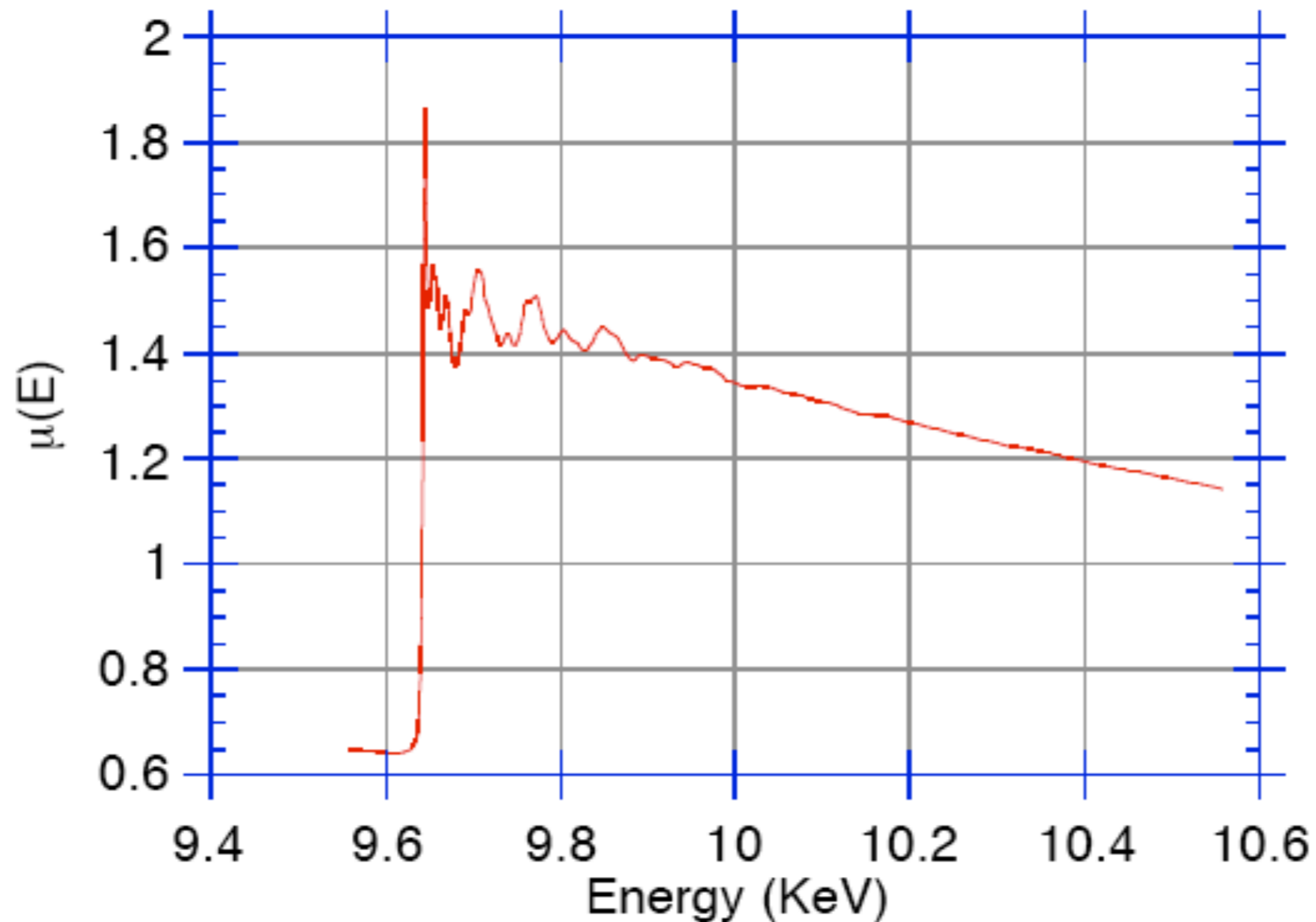
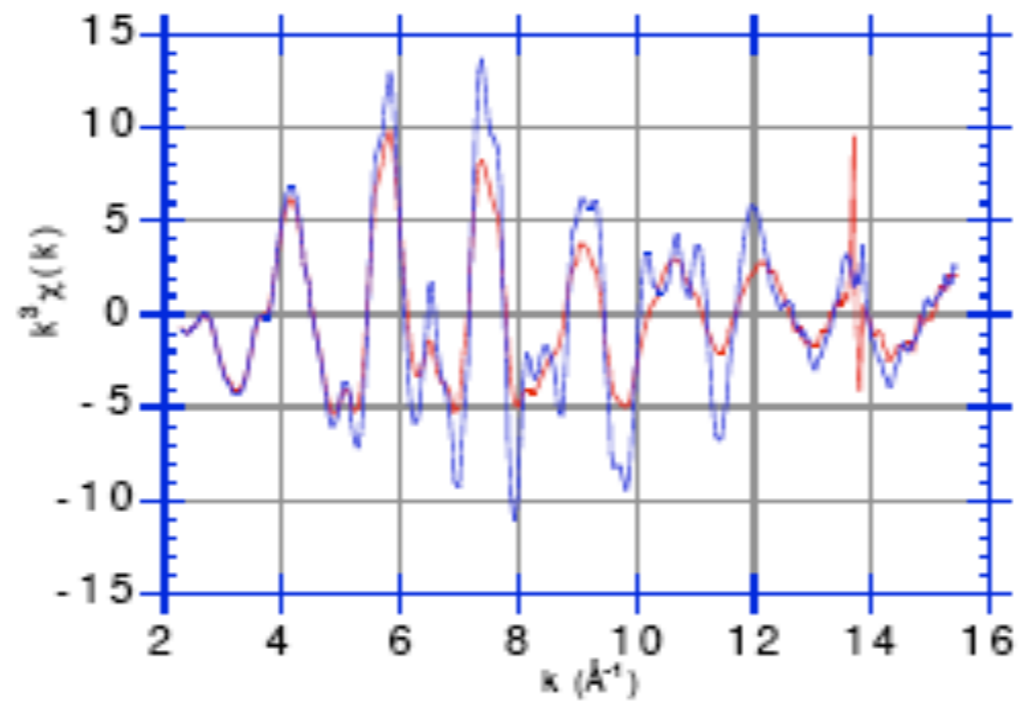

Figure 2 – Transmission XAFS spectrum of ZnS

-> normalize, convert to k space, subtract spline background

k^3 weighted EXAFS



$k^3 \chi$, 300K vs 30K

Fourier Transforms

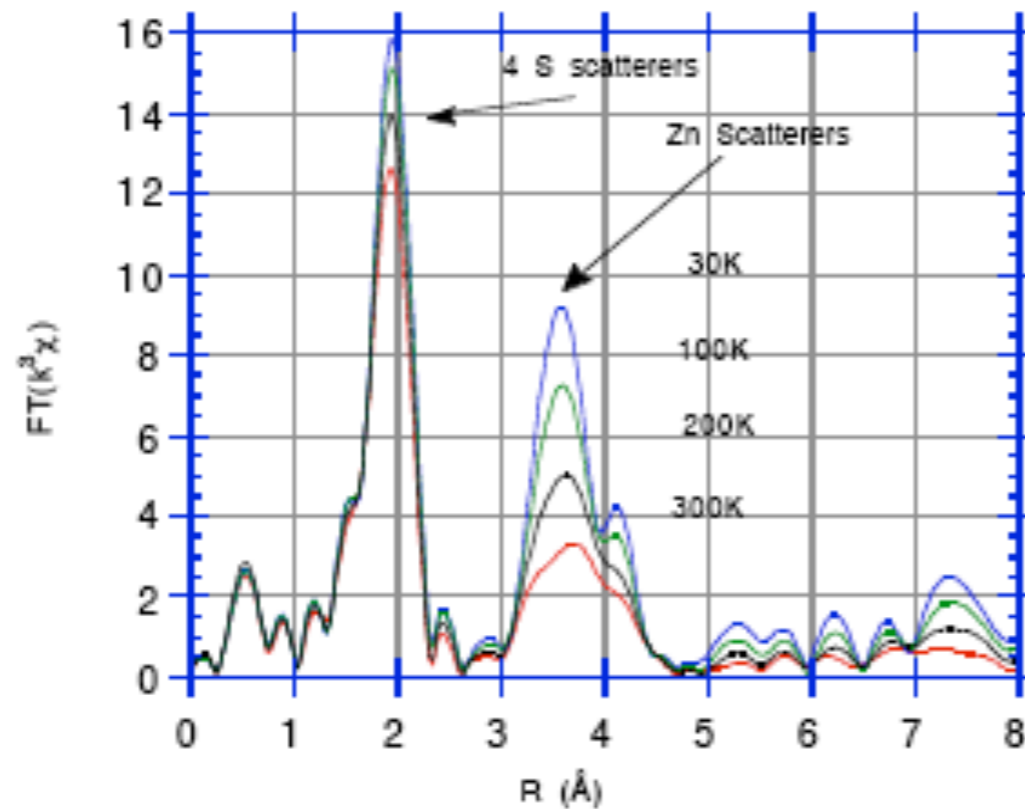

Fourier transforms

Average EXAFS signal amplitude decreases at higher temperatures because of increased thermal EXAFS Debye-Waller Factors

Fourier Filtered First Shell

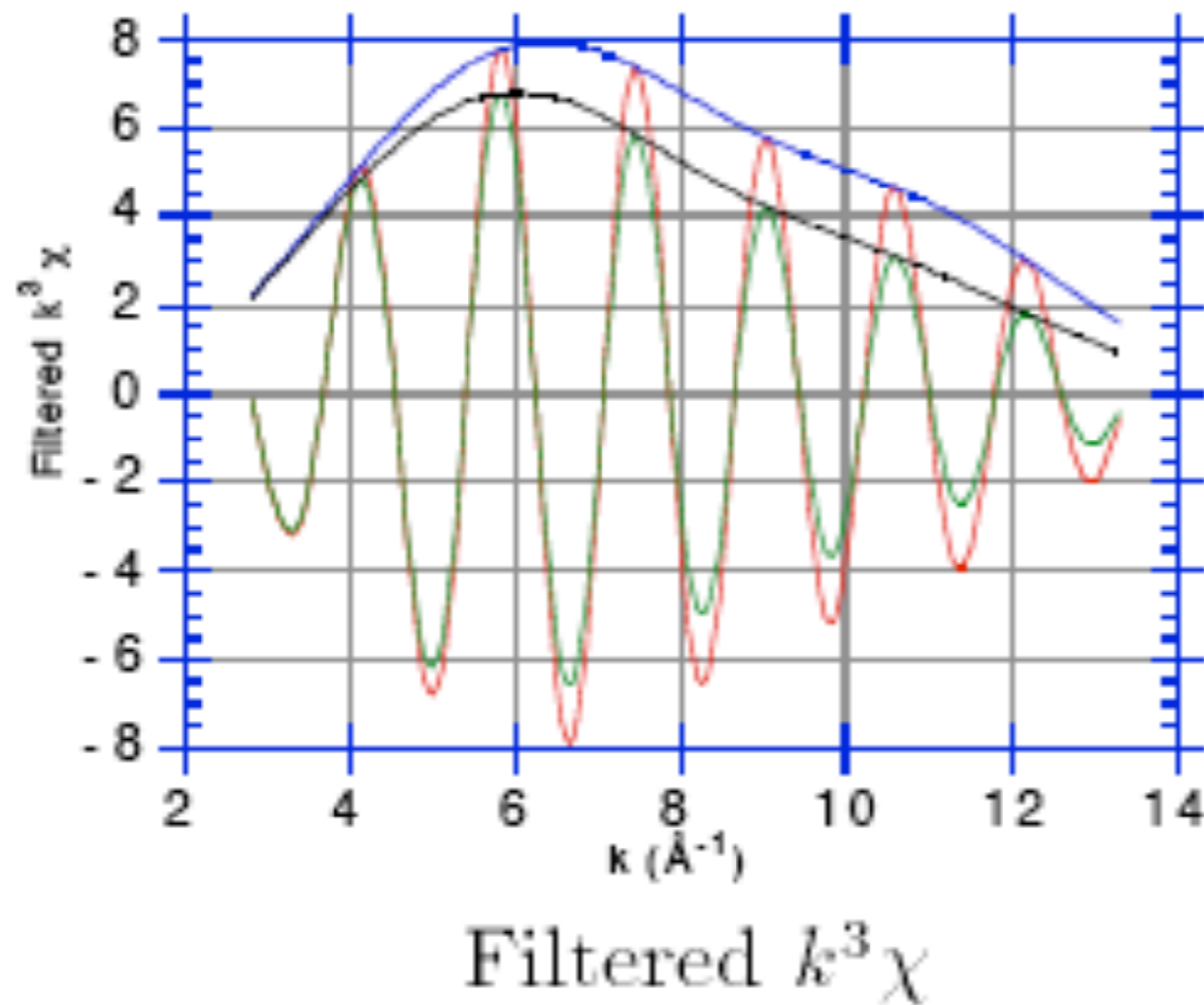

determine single shell's amplitude and phase from real and imaginary parts of inverse FT

Log-Ratio Amplitude

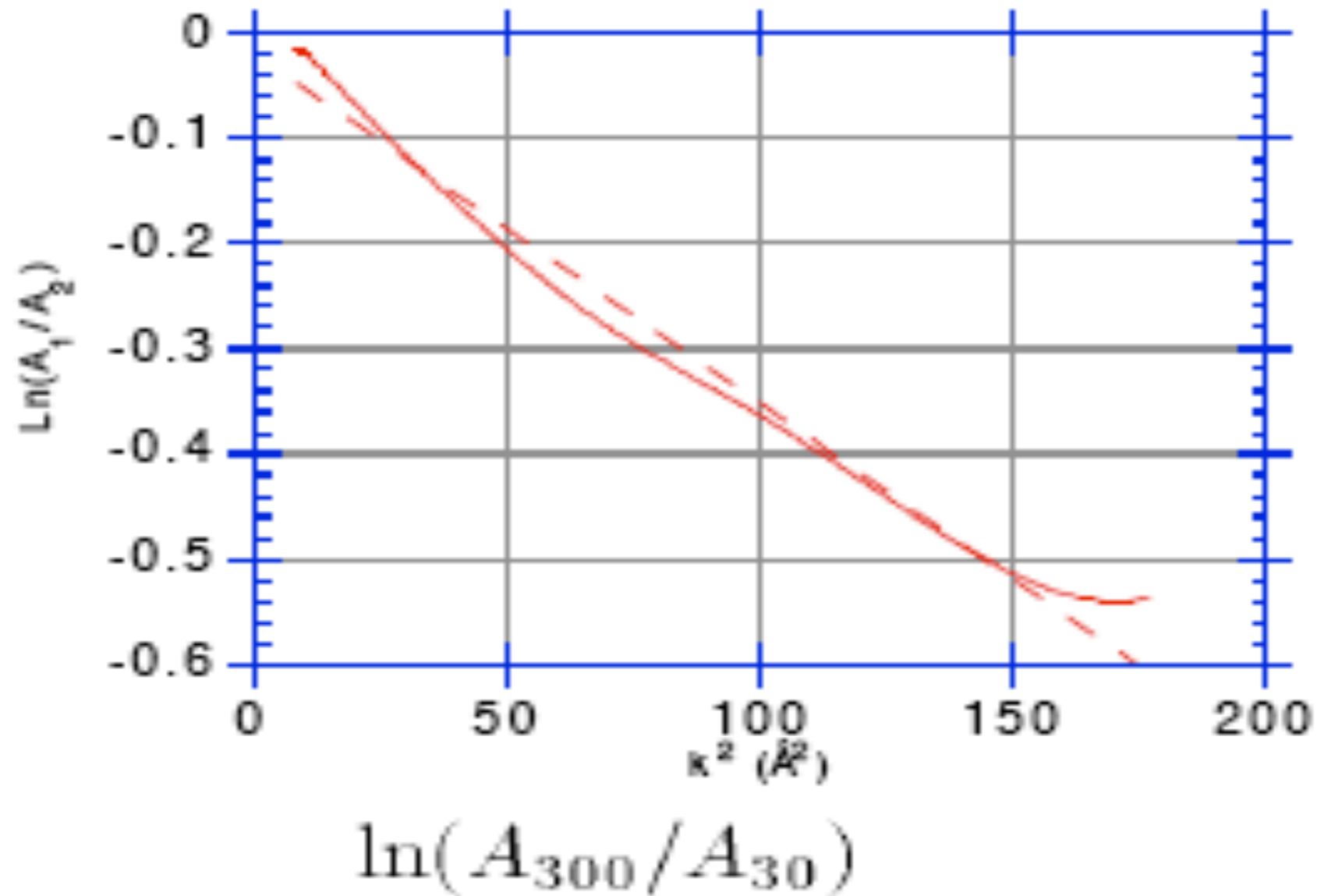

Slope gives difference in σ^2 , intercept gives $\ln[\text{CN ratio}]$ vs reference spectrum

Single Scattering fitting

- If SS is a good approximation, and shells are well isolated, you can fit shell by shell
- Complications still occur because of large disorder, accidental cancellations, and high correlation between fitting parameters
- Multishell fits in SS approximation

Multiple scattering fitting

- MS often cannot be neglected (e.g. focussing effect)
- MS fitting introduces a host of complications but also potential advantages
 - SS contains no information about bond angles
 - MS does contain bond angle information (3-body and higher correlations)
- Parameter explosion -> how to handle DWFs?
 - Dangers of garbage-in, garbage-out
- (more on this later in the talk)

Theory

- Improved Theory and Practical Implementations
 - Fast sophisticated electron multiple scattering codes
 - Still limitations in near-edge (XANES) region
 - Solves the forward problem (structure->spectrum), but not the inverse problem (spectrum -> structure),
 - More work on better fitting direct methods is needed
 - Sophisticated quantum chemistry codes have been made easier to use; they can be leveraged to combine DFT and XAFS
 - correlate electronic and vibrational structure

Computing Multiple Scattering with FEFF9

- ④ {Rewrite golden rule squared matrix element in terms of real-space Green's function and scattering operators; expand GF in terms of multiple scattering from distinct atoms}
- ④ initial atomic potentials generated by integration of Dirac equation (relativistic analog of Schrödinger); modified atomic potentials generated by overlapping (optional self-consistent field; use for XANES)
- ④ complex exchange correlation potential computed -> mean free path
- ④ scattering from atomic potentials described through k-dependent partial wave phase shifts for different angular momentum l
- ④ radial wave function vs E obtained by integration to calculate μ zero
- ④ unimportant scattering paths are filtered out (except FMS)
- ④ Feffs for each path calculated (e.g. Rehr Albers formalism)
- ④ final spectrum generated by summing finite number of paths, or, over restricted energy range, FMS (use for XANES)
- ④ **-> All of this is accomplished in a few seconds**

FEFFx: see papers of Rehr, Ankudinov, Zabinsky et al
see also DLXANES, GNXAS, and EXCURV programs

Example: Multiple Scattering within Histidine Imidazole Ring

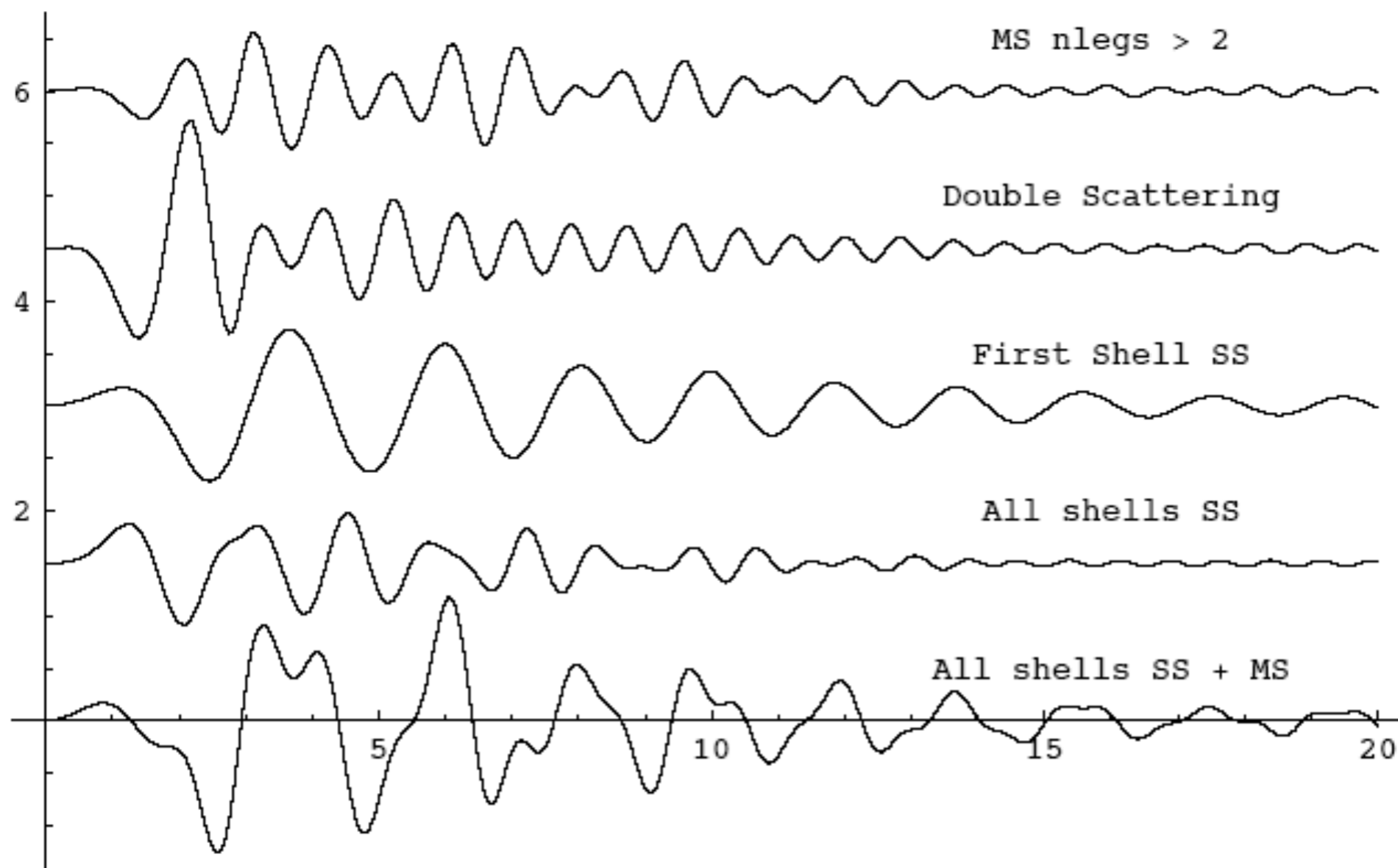
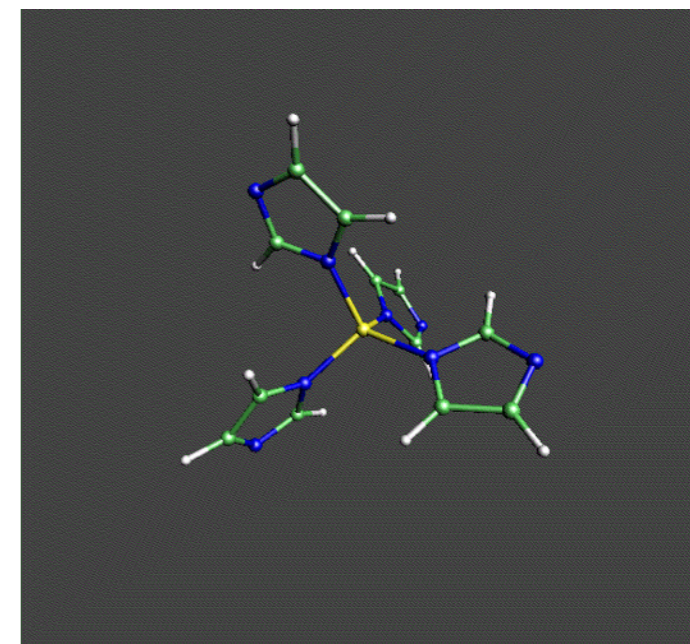

Information content of XAFS spectra is limited

- Estimate from Nyquist criterion
- Assume spectrum completely described as band limited function by finite set of fourier coefficients
- N degrees of freedom = $2 \Delta k \Delta r / \pi$
 - $2 * 10 * 3/\pi \sim 20$ for solution spectra

Parameter explosion in MS fitting

- Multiple scattering expansion
- May be tens or hundreds of important paths
- Each path has degeneracy, pathlength, debye waller factor, ...
- Geometry allows you to interrelate the pathlengths within certain limits
- Group fitting (Hodgson & Co)
- Determining all the MS Debye Waller parameters by fitting is a hopeless task
- What can you do?

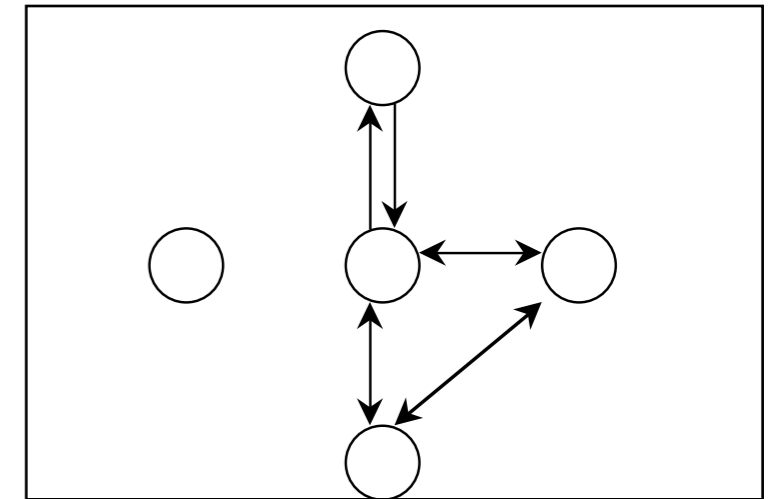

Dealing with Parameter Explosion

- Use a priori information; extend k-space range
- Simultaneous fitting to multiple spectra e.g. different temperatures
- Suppress DWFs by measuring samples cryogenically -> zero point motion and static DWFs
- minimize use of ad-hoc assumptions!
- Calculate DWFs on physical grounds (Dimakis & Bunker, Poiarkova & Rehr) using density functional theory or faster methods
- If you can orient your sample, do it - you can double or triple information for low symmetry sites with polarized XAFS; better yet, joint refinement with XRD

Parameters needed to describe structure

- Neglecting inter-ligand MS, how many parameters needed to define structure for metal protein site?
 - rho, alpha, beta for 4 ligands -> 12 parameters
 - rho, alpha, beta for 6 ligands -> 18 parameters
 - Need more parameters to describe disorder
 - Neglects multiple scattering between ligands
 - Indeterminate or nearly so for 3D structure

Polarized XAFS helps

- Second rank tensor – 3 by 3 matrix - 9 components, each a function of energy
- Diagonalize to 3 independent functions
- Isotropic average in solution (and cubic symmetry) to one independent function – the usual XAFS
- Low symmetry structures – can get up to 3 times the information (~60 parameters) from polarized XAFS
- Can use crystals that are not perfect enough for atomic resolution diffraction
- In principle could solve for 3D active site structure in crystal
- Joint refinement: crystallography and XAFS

Ab initio XAFS: scattering + vibrations

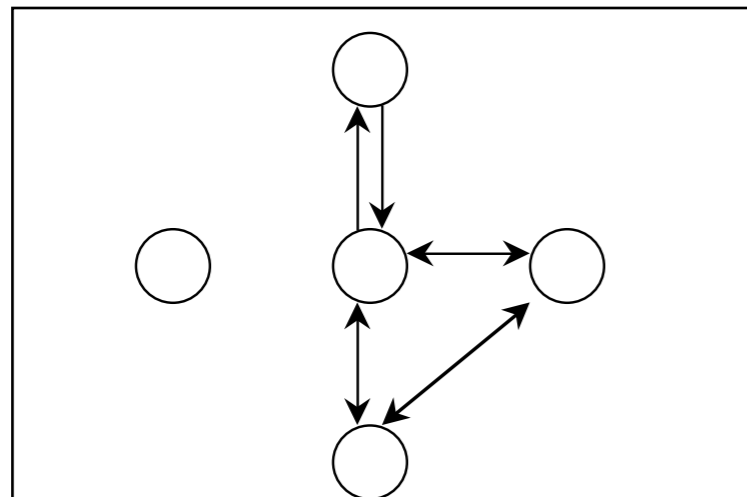

By combining sophisticated electron multiple scattering codes with density functional based quantum calculations of molecular vibrations, one can accurately calculate spectra with no fudge factors

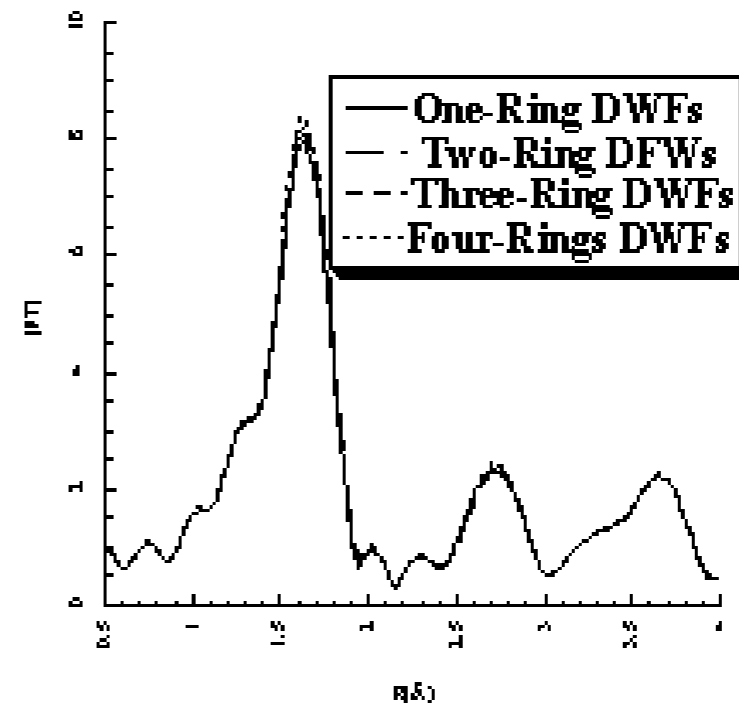

Zn tetraimidazole

His(3),
Cys(1)
Zn site:

Automated
fitting
using a
genetic
algorithm,
+ FEFF7 +
ab initio
DWFs.

(Dimakis
& Bunker,
Biophys. Lett.
2006)

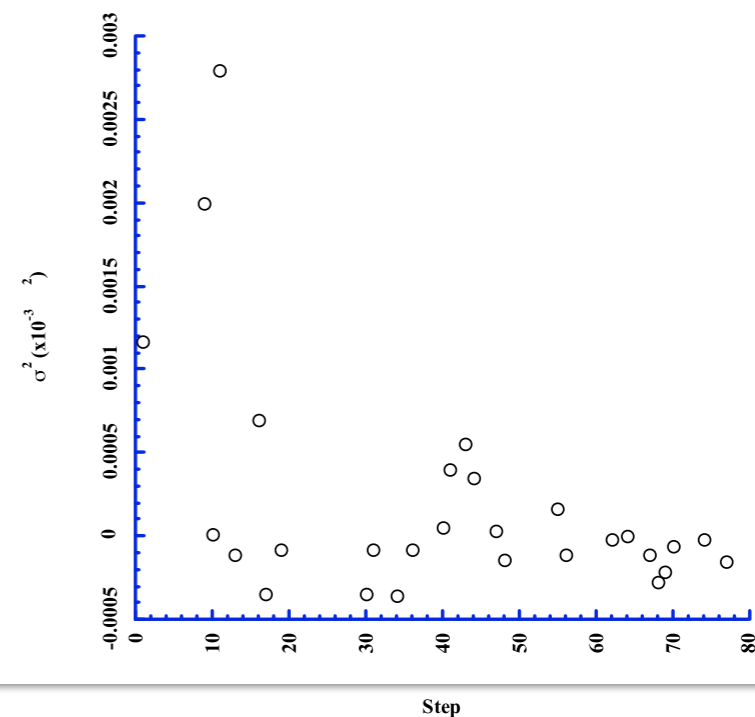
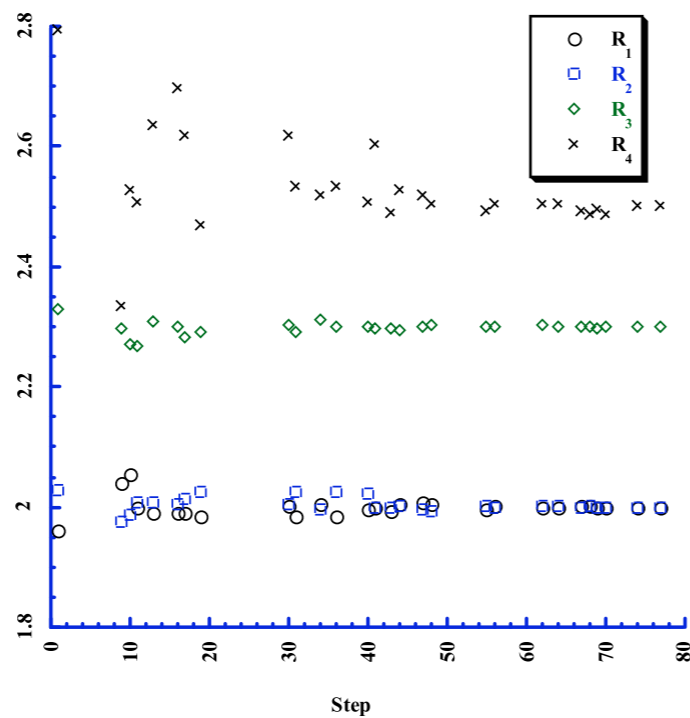
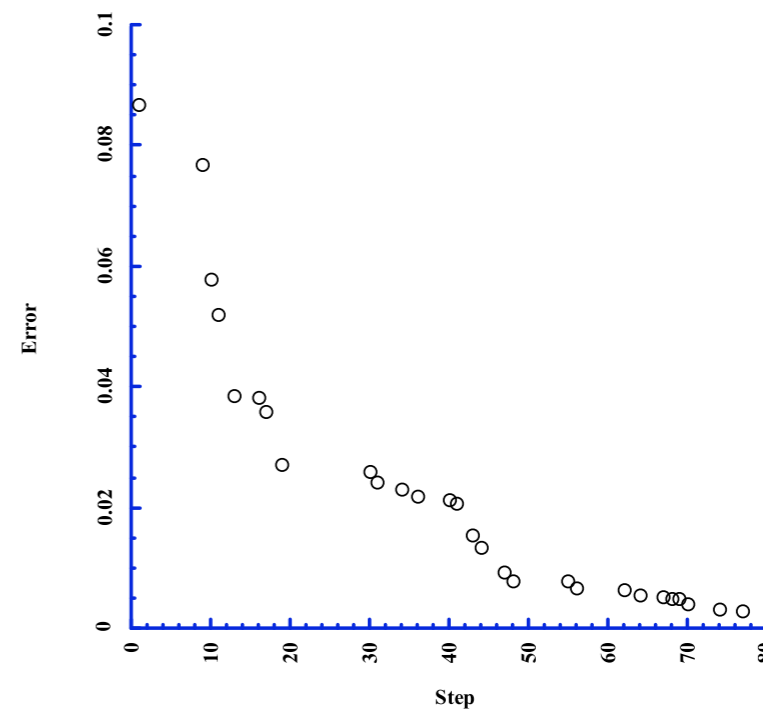
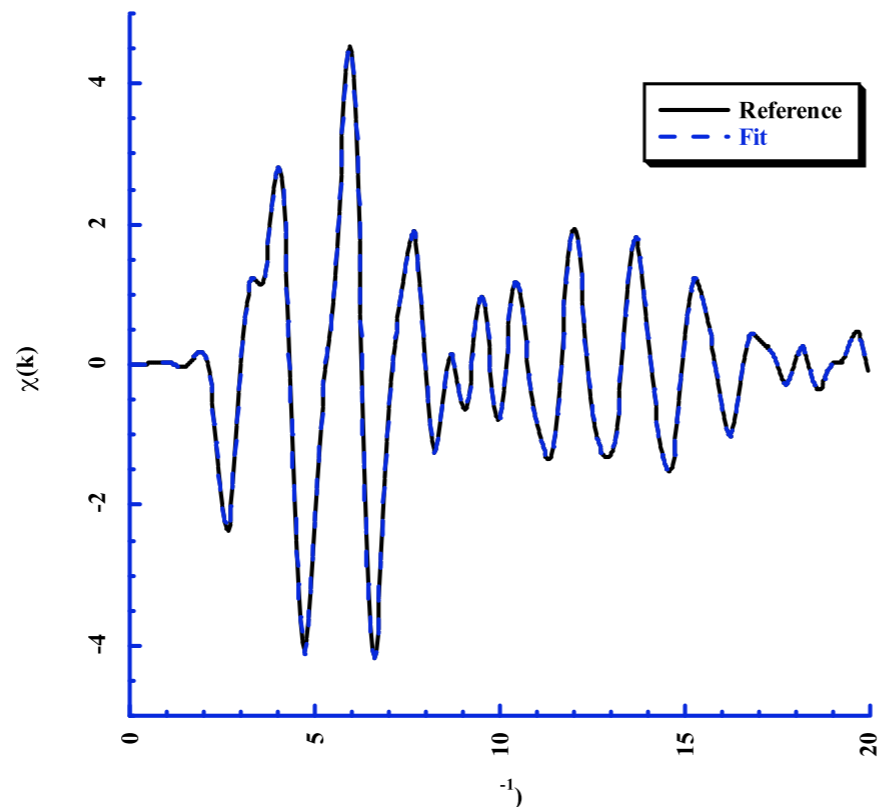

Direct Methods

Direct methods for determining radial distribution functions from EXAFS using Projected Landweber-Friedman Regularization

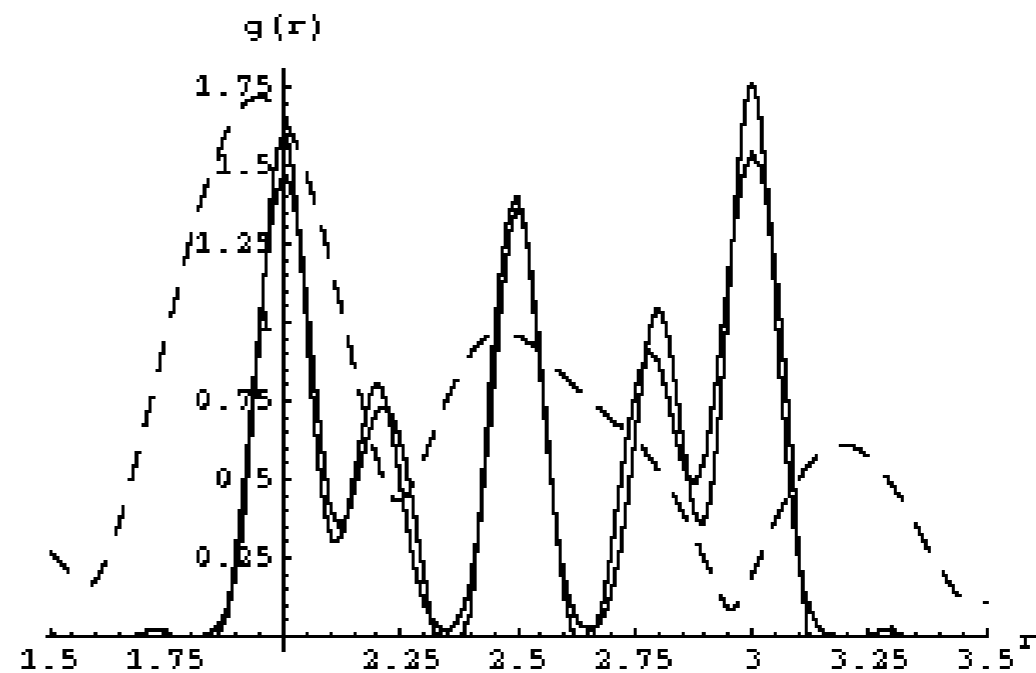
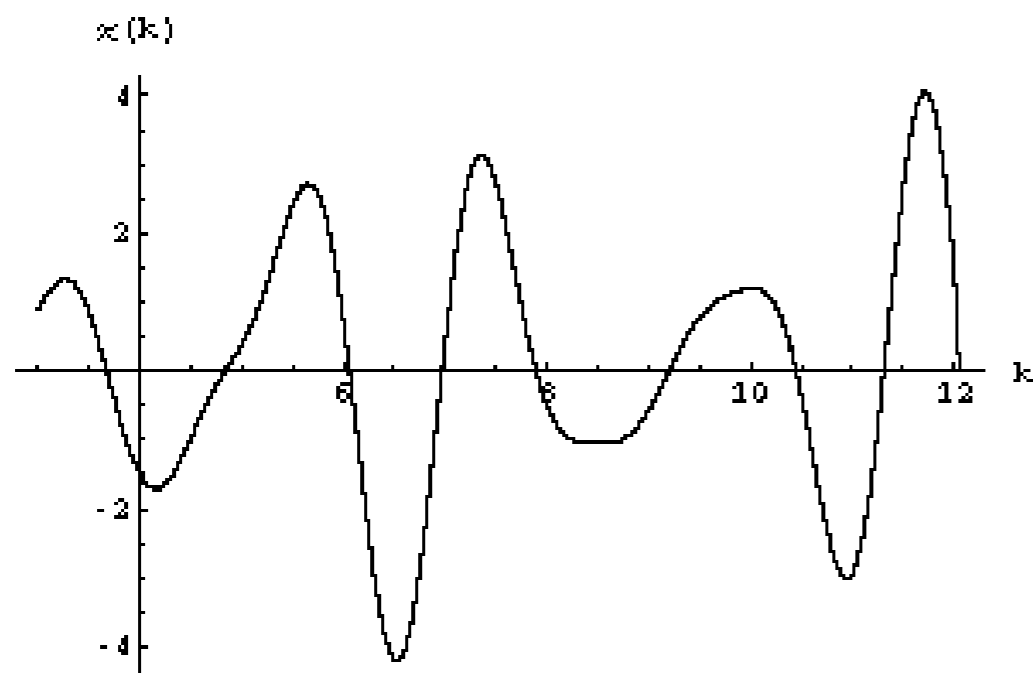

Khelashvili & Bunker

Chemical Speciation

- Mobility and toxicity of metals in the environment strongly depends on their chemical state, which can be probed in situ with XAFS
- Under appropriate conditions, the total absorption coefficient is linear combination of constituent spectra
- Use singular value decomposition, principal component analysis, and linear programming (Tannazi) methods to determine species
- These deliver direct methods for determining speciation
- Nonlinearities arising from particle size effects theoretically and experimentally (Tannazi & Bunker)

Conclusion

- XAFS is a powerful tool for studying the local structure in both disordered and ordered materials.
- Recent advances have made the technique more powerful and flexible. Much more can be and is being done to build upon and exploit recent advances in theory, experiment, and data analysis.
- for more info, see “Introduction to X-ray Absorption Fine Structure Spectroscopy”, G. Bunker, Cambridge University Press (2010)