

# VENUS: Versatile Neutron Imaging Instrument at the Spallation Neutron Source

The world's brightest neutron source could soon shed light on new ways to improve energy efficiency and productivity of industrial and manufacturing applications. At Oak Ridge National Laboratory's (ORNL) Spallation Neutron Source (SNS), VENUS will provide a truly translational research platform that links science to engineering applications and solutions. Harnessing the unique capabilities of the SNS, it will directly connect the structures, properties, and function of complex materials and engineering systems to reveal practical and fundamental answers about their performance under real-world conditions. From scientific discovery to technology development and deployment, VENUS will enable the advancement of additive manufacturing, materials science, biology, building technologies, manufacturing processes, geothermal systems, biofuels, next-generation vehicles, and much more.

## Optimized for basic and applied research

Neutron imaging is a non-invasive, non-destructive technique that is complementary to other methods such as X-ray or gamma imaging and is considered an essential tool in many modern material sciences and engineering applications. The unique combination of the capabilities of VENUS and the intense pulse of the SNS will improve conventional neutron imaging methods and offer novel energy-selective imaging techniques to better understand a wide range of materials, manufacturing, and production processes.

### A Unique Source of Neutrons for the Basic and Applied Scientific Community

Time-of-flight neutrons that are produced from a spallation source provide a unique non-destructive look at materials and engineered material systems. VENUS will provide crystallographic properties (strain, texture, phase), elemental composition and temperature, all in one non-destructive in-situ measurement. VENUS will reveal material and mechanical behaviors during operation and under exposure to extreme conditions such as heat and pressure. Time-of-flight neutrons provide a mechanism for neutron image analysis that is similar to hyperspectral imaging in the optical domain, enabling new ways to probe materials for fundamental research, engineering, manufacturing, geothermal, biomass applications, etc.

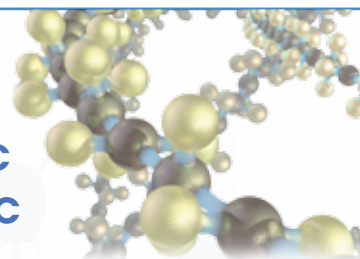

### Advanced Manufacturing

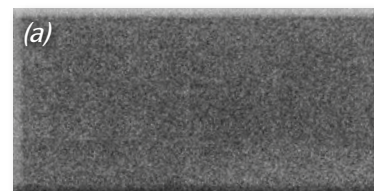

Energy-resolved neutron imaging experiments have been performed at the Oak Ridge National Laboratory Spallation Neutron Source. These measurements demonstrated the future neutron imaging capabilities the VENUS beam line will provide. Additive Manufacturing samples were selected to demonstrate the capability to measure crystallographic properties such as grain orientation and microstructure inside the samples in imaging mode.



Samples of materials made through additive manufacturing. Image (a) is a neutron radiograph using conventional neutron technique (polychromatic beam), while images (b) and (c) are neutron radiographs at two difference neutron wavelengths. The difference in texture leads to differences in a measured transmitted spectrum. The DOE letters are printed with a polycrystalline structure whereas the surroundings are textured with a preferred grain orientation.

### Materials

VENUS will be used to evaluate materials at different stages of manufacturing to improve process design and prevent future waste. For example, understanding the composition of alloys and the impact of impurities on material properties can be achieved through neutron imaging to determine the spatial distributions of alloying materials, magnetic properties, stress/strain, and the distribution, sizing and identification of inclusions and impurities. Additionally, VENUS will enable the development of stronger carbon fiber composites for industrial and other purposes. Advancing the construction of more protective and durable infrastructure, VENUS will enable the study and development of concrete and composite materials with superior mechanical strength. ORNL researchers in collaboration with the Department of Homeland Security used neutron computed tomography to quantify the hydrous and anhydrous phases of ultra-high performance concretes for improved understanding of composite behaviors under normal and extreme environments, such as impacts and fires.

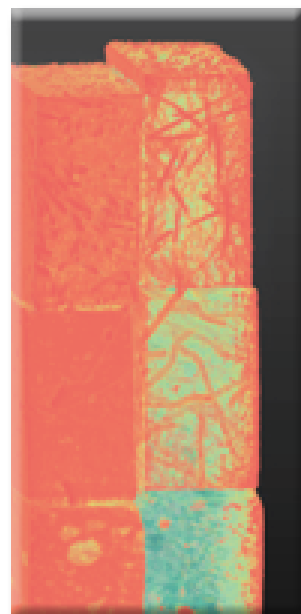

Neutron computed tomographic data sets showing microstructures of conventional and ultra-high performance concretes exposed to different temperatures, which induced a change in phases.

## Accelerating opportunities

Several academia and industry research projects have already benefited from the existing prototype imaging beam line at ORNL's High Flux Isotope Reactor. These projects have shown the importance and the potential impact of forefront neutron imaging capabilities. Some examples are listed in this brochure. The prototype beam line has addressed an influx of user projects with major manufacturers and industry leaders including Ford, GM, Chrysler, Toyota, United Technologies Research Center, Honeywell, Cummins Engines, Detroit Diesel, Mack, Delphi, Navistar, PACCAR, John Deere, Caterpillar, Volvo, GE, Whirlpool, DuPont, Thermacore, Mars, and Bush.

### Energy



Computed Tomography of Li distribution ( $Li_2O_2$ ) in a control battery.

Optimizing lithium-ion transport is a key to improving the power, capacity, and lifetime of batteries. In advanced battery research, the change in lithium concentration in both cathodes and anodes as a function of charge and discharge can be visualized and quantified using neutron imaging techniques that will be available at VENUS.

*"With its predicted higher spatial resolution VENUS could deliver the capability to quickly construct 3D maps that not only show the lithium distribution inside of a real battery electrode at a fixed state of charge, but the higher flux available on the SNS could also enable studies of dynamic behavior in batteries and other vehicle components."*



Andy Drews, Ford Research & Advanced Engineering

### Transportation

VENUS will help predict system behavior and maximize energy efficiency of next-generation vehicles. Its neutron imaging capabilities will lead to development of better spray models and fuel injection systems. Non-invasive energy selective capabilities will allow internal viewing of diesel exhaust systems, while stroboscopic imaging will enable advanced in situ engine experiments and diagnostic research.

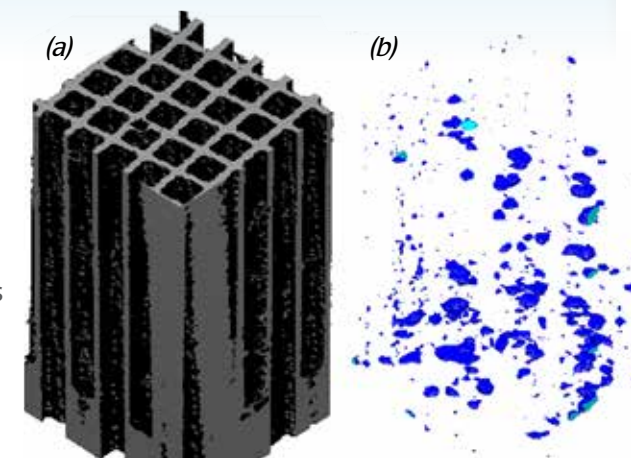

Neutron tomography (3D) slice of diesel particulate filter enables in situ study of particulate matter and ash during steady state and regenerative cycling. The contribution of the (a) walls and the (b) particulate can be separated.



*"Non-destructive analyses of soot and ash distribution accumulated in diesel particulate filters are issues for future and further improvements for emission aftertreatment system management. Neutron imaging is one of the technologies that has potential to solve the issues."*

Shawn Fujii, NGK Automotive Ceramics USA, Inc.

## Designed for practical problems

The design of VENUS will enable direct studies of practical systems in energy production (including renewable, nuclear, and fossil sources), energy storage, fuel cells, hydrogen storage, vehicle technologies, building technologies, and industrial engineering component design.

VENUS will contribute to fundamental scientific understanding in areas such as materials chemistry, physical and mechanical materials behavior, geosciences, plant biology and physiology, biofuel and energy production, and climate change. Advanced materials science and engineering programs will benefit from the availability of VENUS, and the instrument will support additional studies in archaeological, biological, biomedical, forensic, and homeland security applications.

Energy efficiency and renewable energy-related researchers will define a large part of the VENUS applied research user community.

Estimated Beam Characteristics	
Beam Spectrum	Epithermal, Thermal, Cold
Moderator	H <sub>2</sub> decoupled poisoned (sharpest pulse at the SNS)
Wavelength bandwidth	~ 2.4 Å (Time-Of-Flight mode)
Spatial resolution	< 15 microns (a few microns with magnification)
Resolution $\Delta d/d$	0.12%
Source-to-detector distance	25 m
Sample-to-detector distance	A few mm to tens of cm (as needed for magnification)
Detection system and resolution	Camera and Micro-Channel Plate TOF detector (few microns spatial resolution)
Flux on sample (n/s/cm <sup>2</sup> )	1 x 10 <sup>7</sup> in TOF mode 1 x 10 <sup>8</sup> in white beam mode
Field of View	Up to 20 cm x 20 cm (Full illumination) in 2D imaging

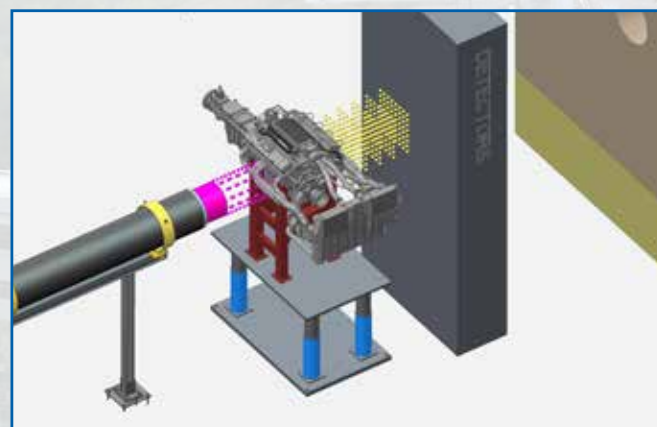

*Stroboscopic imaging set-up of an engine block showing neutrons transmitted through an engine, detected, and finally absorbed by beam stop.*

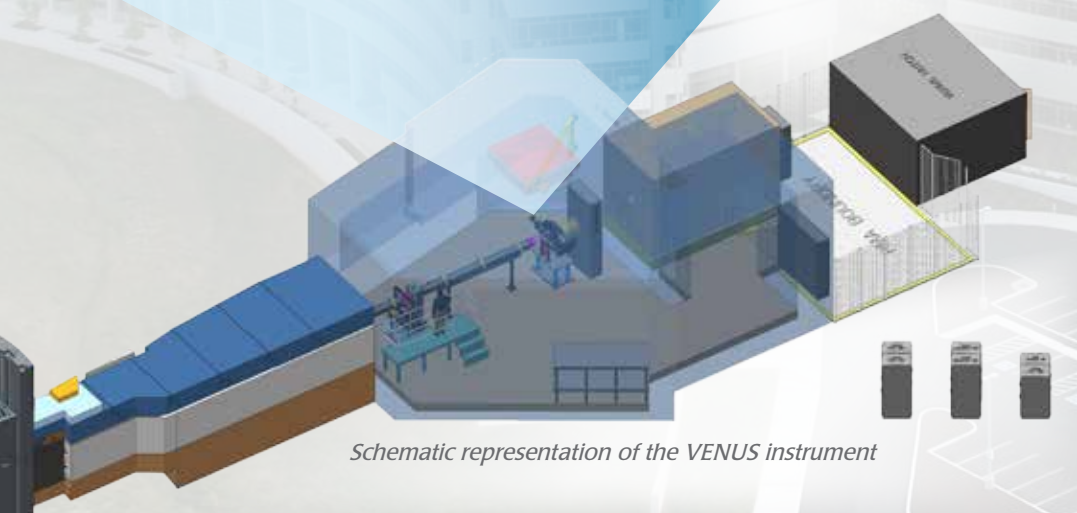

*Schematic representation of the VENUS instrument*

*For more information about VENUS, contact:*



Hassina Bilheux  
VENUS Instrument Scientist  
Neutron Sciences Directorate  
Oak Ridge National Laboratory  
865-384-9630  
bilheuxhn@ornl.gov

<http://neutrons.ornl.gov/venus>

# VENUS on the Horizon

Neutron imaging to enhance advanced manufacturing, energy efficiency, materials science, and industrial research

14-G01337/arm

